

E3000i CONTROLLER

取扱説明書 / OPERATION MANUAL

日本語 : P1 - P76 / English : P77 - P157



Thank you for purchasing the E3000i Ultra-Precision, High-Speed spindle system. The E3000 system was designed for use on CNC lathes, robots, NC lathes and special purpose machines. The motor, spindle and E3000i CONTROLLER are designed to work as an integrated system capable of 80,000 min⁻¹ (rpm). This system utilizes air to cool the motor and protect the spindle. Always use an Air Line Kit to ensure clean, dry, properly regulated air is supplied to the motor and spindle. The E3000 system is capable of being used with coolants and cutting lubricants. Read this and all the associated component Operation Manuals carefully before use. Always keep this operation manual in a place where the user can refer to it at any time.

CONTENTS

| | |
|--|-------------|
| IMPORTANT INSTRUCTIONS AND WARNING - Electric Devices | P78 |
| 1 . CAUTIONS FOR HANDLING AND OPERATION | P79 |
| 2 . BASIC PACKAGE | P83 |
| 3 . WARRANTY | P84 |
| 4 . CONTACT US | P84 |
| 5 . FEATURES | P85 |
| 6 . SPECIFICATIONS AND DIMENSIONS | P86 |
| 7 . SYSTEM CHART | P88 |
| 8 . TORQUE CHARACTERISTICS | P91 |
| 9 . CONTROL PANEL FEATURES | P93 |
| 10. REPLACING FUSES | P96 |
| 11. BRACKET AND RUBBER PAD INSTALLATION | P97 |
| 12. POWER CORD CONNECTION | P99 |
| 13. MOTOR CORD CONNECTION | P100 |
| 14. MOTOR CURRENT DISPLAY FUNCTION AND TIGHTENING WHEN CLAMPING | P100 |
| 15. AIR HOSE CONNECTION AND AIR PRESSURE SETTING | P101 |
| 16. CHANGING THE CONTROL PANEL | P103 |
| 17. OPERATION PROCEDURES | P104 |
| 18. EXTERNAL INPUT / OUTPUT CONNECTOR | P107 |
| 19. PROTECT FUNCTION | P119 |
| 20. SETTING OF OPERATING PARAMETERS | P121 |
| 21. BREAK IN PROCEDURE | P154 |
| 22. CONNECTION WITH E3000 SELECTOR | P154 |
| 23. TROUBLESHOOTING | P154 |
| 24. DISPOSAL OF THE CONTROLLER | P157 |

⚠ IMPORTANT INSTRUCTIONS AND WARNING - Electric Devices

WARNING!

When using electric tools, basic safety precautions should always be followed to reduce the risk of fire, electrical shock and personal injury.

Read all these instructions before operating this product and save these instructions.

A. GROUNDING INSTRUCTIONS

- In the event of a malfunction or breakdown, grounding provides a path of least resistance for electric current to reduce the risk of electric shock. This tool is equipped with an electric cord with a grounding conductor and a grounding plug. The plug must be plugged into a matching outlet that is properly installed and grounded in accordance with all local codes and ordinances.
- Do not modify the plug provided if it does not fit the outlet, A qualified electrician must install the proper outlet.
- Improper connection of the grounding conductor can result in electric shock. The grounding conductor has an outer insulation that is green with or without yellow stripes. If repair or replacement of the electric cord or plug is necessary, do not connect the grounding conductor to a live terminal.
- Check with a qualified electrician or service person if the grounding instructions are not completely understood, or if in doubt as to whether the tool is properly grounded.
- Use only 3-wire extension cords that have 3-prong grounding plugs and 3-pole receptacles that accept the power cord's plug.
- Repair or replace a damaged or worn cord immediately.
- This tool must be used on a circuit that has an outlet that looks like the one illustrated in Sketch A in figure (See below) (115V). The tool has a grounding plug that looks like the plug illustrated in Sketch A in Figure (below).
- FOR Installation in Machine Electrical Cabinet or when wiring directly to machine internal power terminal strip:
 - Please refer to the pin diagram below for the proper wiring configuration. The plug shown is the female plug that attaches to the E3000i CONTROLLER main power inlet.
 - Make sure you test each individual wire to verify proper circuit prior to attaching any wire to the terminal block. Do not assume wire colors are the same for all power cords.
- Install an over current protective device of maximum 10 Amps on the E3000i CONTROLLER main power circuit.
- USE PROPER EXTENSION CORD. Make sure your extension cord is in good condition. When using an extension cord, be sure to use one heavy enough to carry the current your product will draw.

An undersized cord will cause a drop the line voltage resulting in loss of power and overheating.

Table (below) shows the correct size to use depending on cord length and nameplate ampere rating.

If in doubt, use the next heavier gage. The smaller the gage number, the heavier the cord.

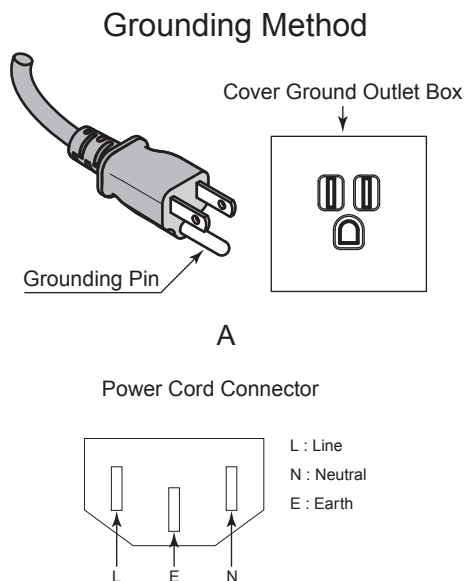

Minimum gage for cord

| Ampere Rating | | Volts | Total length of cord | | | |
|---------------|---------------|--------------|-----------------------------|-----------------------------|------------------------------|------------------------------|
| | | 120V 240V | 7.5m (25ft.) 15m (50ft.) | 15m (50ft.) 30m (100ft.) | 30m (100ft.) 60m (200ft.) | 45m (150ft.) 90m (300ft.) |
| More Than | Not More Than | | | | | |
| 0 | 6 | 18 | 16 | 16 | 14 | |
| 6 | 10 | 18 | 16 | 14 | 12 | |
| 10 | 12 | 16 | 16 | 14 | 12 | |
| 12 | 16 | 14 | 12 | Not Recommended | | |



Only the applicable parts of the Table need to be included. For instance, a 120-volt product need include the 240-volt heading.

B. OTHER WARNING INSTRUCTIONS

1. For your own safety read instruction manual before operating this tool.
2. Replace cracked collet or collet nut immediately.
3. Do not over tighten the collet nut.
4. Use only NAKANISHI manufactured collets and arbors for grinding and sawing applications.
5. REMOVE ADJUSTING KEYS AND WRENCHES. Always check to see that keys and adjusting wrenches are removed from tool before turning the units Main Power Switch on.
6. KEEP WORK AREA CLEAN. Cluttered areas and benches invite accidents.
7. DO NOT USE IN DANGEROUS ENVIRONMENTS. Don't use power tools in damp or wet locations, or expose them to rain.
8. Keep work area well lighted.
9. There is a risk of injury due to accidental starting. Do not use in an area where children may be present.
10. DO NOT FORCE THE TOOL. Never use a tool for an application it was not designed for.
11. USE THE CORRECT TOOL. Do not force tools or attachments to do a job for which it was not designed.
12. WEAR PROPER APPAREL. Do not wear loose clothing, gloves, neck ties, rings, bracelets, or other jewelry that might get caught in moving parts. Nonslip footwear is recommended. Wear protective hair covering to contain long hair.
13. ALWAYS USE SAFETY GLASSES. Everyday eyeglasses only have impact resistant lenses, they are NOT safety glasses. Also use face or dust mask if cutting operation is dusty.
14. SECURE YOUR WORK. Use clamps or a vise to hold work securely at all times.
15. MAINTAIN TOOLS WITH CARE. Keep tools sharp and clean for best performance and to reduce the risk of injury. Follow instructions for changing accessories.
16. DISCONNECT TOOLS before servicing or when changing accessories, such as blades, cutters etc.
17. REDUCE THE RISK OR UNINTENTIONAL STARTING. Make sure Main Power Switch is in OFF position before plugging in.
18. NEVER LEAVE TOOLS RUNNING UNATTENDED. TURN POWER OFF. Don't leave the tool until it comes to a complete stop.
19. For recommended operating speeds for various applications, please follow recommendations of the cutting tool manufacturer.

1. CAUTIONS FOR HANDLING AND OPERATION

- Read these warnings and cautions carefully and only use in the manner intended.
- These warnings and cautions are intended to avoid potential hazards that could result in personal injury or damage to the device. These are instructions are classified as follows in accordance with the seriousness of the risk.

| Class | Degree of Risk |
|---|---|
|  DANGER | Existence of a hazard that could result in personal death or serious injury, if the safety precautions are not followed. |
|  WARNING | A hazard that could result in bodily injury or damage to the device if the safety instructions are not properly followed. |
|  CAUTION | A hazard that could result in light or moderate bodily injury or damage to the device if the safety instructions are not followed. |

DANGER

- ① Be sure to cut off power supply before attaching / detaching the Power Cord and motor cord. Attaching / detaching the Power Cord or motor cord with power supplied may cause an electric shock resulting in death or serious injury.
- ② Turn all the power supplies OFF before wiring. Wiring while power supply is ON may cause an electric shock resulting in death or serious injury.
- ③ Be sure to connect the ground wire of the Power Cord to earth ground. Failure to do so may cause an electric shock, malfunction, or fire.
- ④ Do not rotate the machining center's main spindle with the HES installed. Rotating the machining center's main spindle with the HES installed can cause the motor cord to become tangled and pull the CONTROLLER off its mounting.

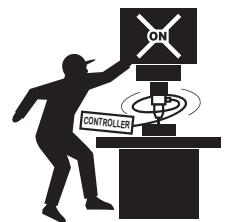

WARNING

- ① The **CONTROLLER** is not a hand tool. It is designed to be used on a CNC lathe or special purpose machines.
- ② Do not touch the cutting tool while the spindle and tool are rotating. It is very dangerous.
- ③ Wear safety glasses, dust mask, and use a protective cover around the motor spindle whenever the motor spindle is rotating.
- ④ Never connect, disconnect or touch the Power Cord Plug or Motor Cord Plug with wet hands. This may cause an electric shock.
- ⑤ Never operate or handle the **CONTROLLER** and motor or spindle until you have thoroughly read the Operation Manuals and safe operation has been confirmed.
 - 1) To prevent injuries / damages, check the **CONTROLLER**, motor spindle and cutting tool for proper installation, then operate the **CONTROLLER**, motor and spindle.
 - 2) Before disconnecting the **CONTROLLER** or motor spindle, always turn the control power **OFF** and turn the compressed air supply to the **CONTROLLER OFF**. Then it is safe to remove the **CONTROLLER** and motor spindle.
- ⑥ Do not use in dangerous environments. Protect the **CONTROLLER** from moisture and other contaminants. Failure to protect **CONTROLLER** can result in damage to internal components and injury to the operator.
- ⑦ To protect the **CONTROLLER** or electrical wiring from a possible short circuit, place a circuit breaker (MCCB) between the power source and the AC POWER Input Terminal of the **CONTROLLER**. Select a 5A circuit breaker, complying with the safety standards UL 489 / EN 60947.
- ⑧ Reduce the risk of unintentional starting. Make sure the Main Power Switch is in the OFF position before connecting the **CONTROLLER** or plugging the system in.
- ⑨ The plug must be plugged into a matching outlet that is properly installed and grounded in accordance with all local codes and ordinances.
- ⑩ Check to ensure that the supply voltage is the same as the **CONTROLLER** rated voltage.
- ⑪ When installing a tool, tighten the collet correctly and check again the collet and collet nut before use. Do not over tighten the collet. This may cause damage to the spindle.
- ⑫ Do not use bent, broken, chipped, out of round or sub-standard tools, as this may cause them to shatter or explode. Tools with fractures or a bent shank will cause injury to the operator. When using a new tool, rotate it in a low speed and increase speed gradually for safety.
- ⑬ Do not exceed the maximum recommended allowable tool speed. For your safety, use speeds below the maximum allowable speed.
- ⑭ Do not apply excessive force. This may cause tool slippage, tool damage, and injury to the operator, loss of concentricity and precision.
- ⑮ When installing the motor and the spindle, make sure the Main Power Switch of the **CONTROLLER** is turned OFF before installing.
- ⑯ When installing a motor spindle to a fixed base, make sure the fixed base is grounded in order to avoid the risk of an electric shock.
- ⑰ Use a power cable that satisfies the prescribed safety standards and local electrical codes for your country. Also select the proper cable size considering the input voltage and current.
- ⑱ When using a motor for iSpeed5, air pressure is not detected. Be sure to supply air for cooling the motor spindle and for air purging.

CAUTION

- ① Prepare a grounded power cord that has adequate voltage and current rating authorized by your country / region.
- ② A motor cooling and spindle purge air is required to operate the system correctly. The input air line must be connected to the air inlet joint on the front of the **CONTROLLER**. Air pressure between 0.2 - 0.5MPa (29 - 72.5psi) must be supplied.
- ③ The brushless motor spindle requires air for cooling and purging. Ensure that this air supply is clean and dry. Introduction of dust, moisture and other contaminants into the **CONTROLLER** and motor spindle will cause damage to the internal components.
- ④ If water or oil is allowed to enter the **CONTROLLER**, failure of the **CONTROLLER** may result.

⚠ CAUTION

- ⑤ Do not hit, drop or subject the motor spindle or CONTROLLER to any type of shock. This will cause damage to internal components and result in a malfunction.
- ⑥ Do not disassemble, modify or attempt to repair the CONTROLLER or motor spindle as it will damage internal components. There are no user serviceable parts available.
- ⑦ Never place the air vents upward or block the air vents of the CONTROLLER when installing.
- ⑧ Set the parameter suitable for the motor to use.
- ⑨ Motor will make a sudden stop when Error LED lights or error output signal is generated. Check and correct the cause of the malfunction before continuing use. Failure to correct the problem will result in damage to the CONTROLLER and motor spindle.
- ⑩ When the warning LED on the CONTROLLER blinks, conditions exist that could result in dangerous operation. Check operating conditions and continue to use only after correcting the problem.
- ⑪ When using CONTROLLER continuously, refer to continuous area on torque Characteristics Graph and check LOAD Monitor LED for a maximum output (3 Blue Lamps).
- ⑫ Do not install the system next to RF noise sources, as malfunctions can occur.
- ⑬ If smoke, noise or strange odors emanate from the CONTROLLER or motor spindle, immediately turn OFF the Main Power Switch.
- ⑭ Do not place anything on top of the CONTROLLER.
- ⑮ When installing the CONTROLLER, never place them in areas where vibration and shock are present or possible. This may cause a malfunction to occur.
- ⑯ When using in a place where the power conditions are poor, take measures to enable a supplied input power within the specified voltage fluctuation.
- ⑰ Do not place the CONTROLLER near any source of heat. The temperature inside the CONTROLLER will rise, resulting in a CONTROLLER failure.
- ⑱ Attach the provided Connector Cover for safety and dust proofing when not using Input / Output Connector A/B or Serial I/F Connector.
- ⑲ When a motor is not connected to Motor Connector No. 1 or No. 2, attach the supplied connector cap for safety and dust proofing to the connectors.
- ⑳ When operation the Control Panel during operation, be careful not to discharge static electricity to the Control Panel.
- ㉑ Do not press the switches on the operation panel of the CONTROLLER with a sharp-pointed tool.
- ㉒ When using SELECTOR with CONTROLLER, please use E3000 SELECTOR.
- ㉓ When disposal of a CONTROLLER is necessary, follow the instructions from your local government agency and dispose as an industrial waste.
- ㉔ Select suitable products or tools for all applications. Do not exceed the capabilities of the spindle or tools.
- ㉕ Do not stop the supplied cooling air to the motor, spindle, motor spindle, during operation of the machine.
Removing the air pressure from the motor, spindle, motor spindle, causes a loss of purging, allowing the motor, spindle, motor spindle, to ingest coolant and debris. This will cause damage to the motor, spindle, motor spindle.
- ㉖ Carefully direct coolant spray to the tool. Do not spray directly on the spindle body. If large amount sprayed directly on the spindle, it may cause excess load of the motor rotation with loss of durability to the motor / spindle.
- ㉗ Stop working immediately when abnormal rotation or unusual vibration are observed. Afterwards, please check the content of Section " 23. TROUBLESHOOTING ".
- ㉘ Always check if the tool, collet or collet nut are damaged before and after operating.
- ㉙ After installation, repair, initial operation, or long periods of non operation, please refer to Operation Manual on the spindle / motor spindle detailed in " 21. BREAK-IN PROCEDURE ". When checking the spindle, no vibration or unusual sound should be observed during rotation.
- ㉚ If the power cord is damaged, replace it with a certified power cord with grounding of sufficient voltage and current rating.
- ㉛ After inserting the Power Cord Plug into the Main Power Inlet with Power Supply Fuses, be sure to fix the Power Cord Plug with the supplied Power Cord Hook so that it does not easily come off.
- ㉜ Setting parameters allows a motor to rotate without air supply. When doing so, be careful of the heat generated by the motor.



CAUTION







- ③③ **Before replacing the Control Panel, cut off the power supply to the CONTROLLER. Also, be careful not to discharge static electricity.**
- ③④ **If there is possibility of falling or dropping of this product, fix this product with the supplied attaching brackets for safety.**
- ③⑤ **Before setting the rotation speed of the motor spindle, check the maximum rotation speed described in the operation manual of the motor spindle. Rotation exceeding the maximum rotation speed may cause abnormal heating, shortened lifetime or breakdown.**
- ③⑥ **When using this product with a mass production machine, be sure to prepare a spare CONTROLLER in case of breakdown.**
- ③⑦ **Securely connect the piping hose and air hose. Failure to do so may cause the hose to move wildly.**
- ③⑧ **Before replacing tools or specified fuses, cut off the power supply to the CONTROLLER.**
- ③⑨ **Do not use this product in a room with a risk of explosion or near flammable materials.**
- ④⑩ **For maintenance and repair, send this product to us.**
- ④① **Use this product in an environment of pollution degree class 2.**

2. BASIC PACKAGE

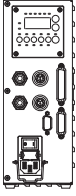
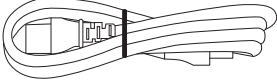
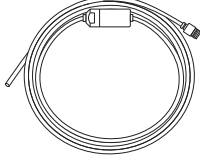
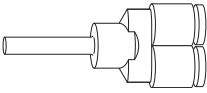
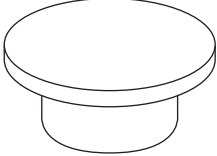
When opening the package, check if it includes all items listed in " Table.1 Packing List Contents ".

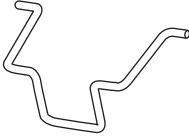
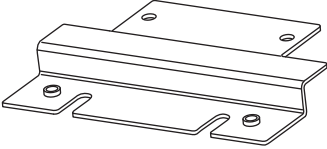
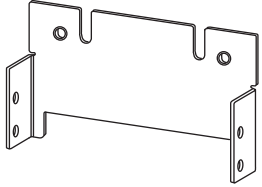
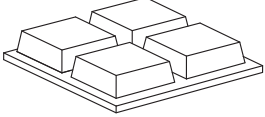
In the event of any shortage, please contact either NAKANISHI (see the " 4. CONTACT US " section) or your local dealer.

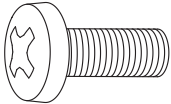
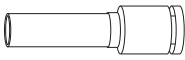
Table. 1 Packing List Contents

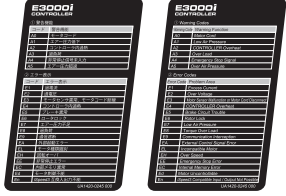
| | | |
|--|--|---|
| <p>E3000i CONTROLLER Main Body • • 1pc.</p>  | <p>Power Cord • • 1pc.</p>  | <p>φ6mm Air Hose with Filter • • 1pc.</p>  |
| <p>Branch Adapter • • 1pc.</p>  | <p>Connector Cap • • 2pcs.*1</p>  | <p>Connector Cover A Connector Cover B Serial I/F Connector Cover • • 1pc. Each.*1</p>  |
| <p>Power Cord Hook • • 1pc.</p>  | <p>Bracket (for bottom) • • 2pcs.</p>  | <p>Bracket (for rear) • • 2pcs.</p>  |
| <p>Rubber Pad (4pcs.) • • 1set</p>  | <p>Fuse • • 2pcs.</p>  | <p>Mounting Screw • • 8pcs.</p>  |
| <p>Reducer (φ6 - φ4 Conversion Adapter) • • 1pc.</p>  | <p>Operation Manual • • 1set</p>  | <p>WARNING / Error Code Label • • 1set*2</p>  |

*1 The Connector Cap, Connector Cover A / B, and Serial I / F Connector Cover are attached to the CONTROLLER.

*2 Do not attach the labels on the CONTROLLER.

3. WARRANTY

We provide a limited warranty for our products. We will repair or replace the products if the cause of failure is due to the following manufactures defects. Please contact us or your local distributor for details.

- (1) Defect in manufacturing.
- (2) Any shortage of components in the package.
- (3) Where damaged components are found when initially opening the package.
(This shall not apply if the damage was caused by the negligence of a customer.)

4. CONTACT US

For your safety and convenience when purchasing our products, we welcome your questions. If you have any questions about operation, maintenance and repair of the product, please contact us.

Contact Us

● For U.S. Market

Company Name : **NSK America Corp.**
Industrial Div.
Business Hours : 8:00 to 17:00 (CST)
(closed Saturday, Sunday and Public Holidays)
U.S. Toll Free No. : +1 800 585 4675
Telephone No. : +1 847 843 7664
Fax No. : +1 847 843 7622
Website : www.nskamericacorp.com

● For Other Markets

Company Name : **NAKANISHI INC.** 
Business Hours : 8:00 to 17:00 (JST)
(closed Saturday, Sunday and Public Holidays)
Telephone No. : +81 289 64 3520
e-mail : webmaster-ie@nsk-nakanishi.co.jp

5. FEATURES

- ① A high-speed brushless motor is used to achieve a maximum speed of 80,000 min⁻¹ (rpm) (when using EM-3080J) and eliminate the need for motor brush maintenance.
- ② Speed control and protection functions utilize a high performance microprocessor.
- ③ Automatic control and monitoring of spindle functions are possible.
- ④ Wide speed range, 1,000 - 80,000 min⁻¹ (rpm) makes high precision machining possible.
- ⑤ Compact CONTROLLER design allows easy installation in space restricted machines. Connectors and control panel are front mounted for easy access.
- ⑥ The CONTROLLER is capable of being connected to AC100V or AC240V power sources. The Auto Sensing feature reduces installation time and eliminates the possibility of connecting the wrong voltage.
- ⑦ The CONTROLLER has a wide speed range of 1,000 to 80,000min⁻¹ (rpm), and a three-digit digital display allows you to set the speed in unit of 200min⁻¹ (rpm).
- ⑧ The Control Panel can be attached on either front or rear side.
- ⑨ Two motor spindles can be connected to the CONTROLLER, enabling you to switch them.
- ⑩ The motor current display function enables you to check the status of load to the motor, perform motor daily inspection, and prevent excessive tightening when attaching the motor spindle to a machine. Also, the key hold function enables you to prevent misoperation due to unintended contact to the Control Panel buttons.
- ⑪ The air pressure display function enables you to check the input air pressure.
- ⑫ The parameter function that specifies motor operations, etc. enables you to motor driving suitable for each usage.
- ⑬ E3000 / iSpeed3 motors are automatically recognized when connected. You can use them without any special settings. E2280 / iSpeed5 motors can be used by setting the parameter function.
- ⑭ This product is compatible with the E3000 CONTROLLER and can be used as a direct replacement for E3000 CONTROLLER.
- ⑮ Using parameter function can make external input / output E2280 / iSpeed3 / iSpeed5 compatible with that of this product, enabling replacement with an existing product other than E3000.
- ⑯ By setting parameter to output warnings / error codes, you can check the warnings and errors by external output, instead of viewing the Control Panel ② .
- ⑰ By setting the parameter $\boxed{\text{P} \quad \text{!} \quad \text{!}}$, Emergency Operating Function can be utilized. Using the open detection signal of the motor power line and the disconnect of the motor power line by safety relay, allows the E3000i CONTROLLER to establish a safe spindle system.
- ⑱ By setting parameter $\boxed{\text{P} \quad \text{2} \quad \text{2}}$, the CONTROLLER is capable of storing the last 10 Error Codes that were displayed. This allows Error Codes to be reviewed if no one is present when the error occurs. Error History will be stored to the CONTROLLER, even if the Main Power Switch is turned OFF.
- ⑲ The parameter function enables you to check the Motor Usage Cumulative Time.

6. SPECIFICATIONS AND DIMENSIONS

6 - 1 Specification of the CONTROLLER

| | | |
|--|----------------------|--|
| Product Name | | E3000i CONTROLLER |
| Model | | NE354 |
| Input Voltage | | AC100 - 240V, 50 / 60Hz, 1PHASE, 2.0A |
| Input Voltage fluctuation | | MAX. +/- 10% |
| Output | | AC33.5V, 0 - 1.33kHz, 3 PHASE, 3.2A |
| Speed Range | | 1,000 - 80,000min ⁻¹ (rpm) *Note 1 |
| Over Voltage Category | | II |
| Short Circuit Current Rating | | 63A |
| Pollution Degree | | Class 2 |
| External Control Signal | Input Signal | Input : Digital 9 (Photo Coupler) Analog 1 |
| | Output Signal | Output : Photo Coupler 1, MOS Relay 9 Relay Contact 2, Analog 3 |
| Protection Function | | Excess Current, Over Voltage, Motor Sensor Malfunction, CONTROLLER Overheat, Brake Circuit Trouble, Rotor Lock, Low Air Pressure, Torque Over Load, Communication Interception, External Control Signal Error, Incompatible Motor, Over Speed, Emergency Stop Error, Internal Memory Error |
| Weight | | 3.0kg |
| Dimensions | | W 88 x D155 x H238 mm |
| Operation Environment | Temperature | 0 - 40°C |
| | Humidity | MAX.75% (No condensation) |
| | Atmospheric Pressure | 800 - 1,060hPa |
| Installation Area | | Indoor use |
| Transportation and Storage Environment | Temperature | -10 - 50°C |
| | Humidity | 10 - 85 % |
| | Atmospheric Pressure | 500 - 1,060hPa |
| Height above Sea Level | | Less than 2,000m |

* Note 1 : Motor Speed Limited Area

Motor Speed limits depend on the Motor Model. Before using it, check the specifications of the motor and the motor spindle. Since CONTROLLER will automatically recognize the motor types, there is no need to adjust the maximum rotation speed based on the motor model.

- Models with Motor Speed limits of 1,000 to 80,000min⁻¹ (rpm) (Usable Motor Speed ranges from 20,000 to 80,000min⁻¹ (rpm)): EM-3080J, HES810, BM-319, BM-320, etc.
- Models with Motor Speed limits of 10,000 to 80,000min⁻¹ (rpm): BM-1680RA, BM-1580RA.
- Models with Motor Speed limits of 1,000 to 60,000min⁻¹ (rpm): BMF-3160-CTZ, EM-3060, EM25-S6000, BM-322, etc.
- Models with Motor Speed limits of 1,000 to 50,000min⁻¹ (rpm): EM-25N-5000, HES510, EM-2350J *Note 2, etc.
- Models with Motor Speed limits of 1,000 to 32,000min⁻¹ (rpm): EMA-3020K, EMA-3020S, etc.
- Models with Motor Speed limits of 1,000 to 30,000min⁻¹ (rpm): BMF-3130-CTZ, EM-3030T-J, etc.

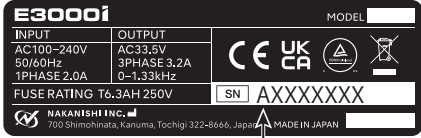
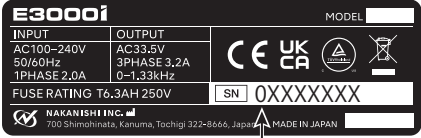

* Note 2 : For EM-2350J, setting on Parameter **P 1E** is required.

Table. 2 Identifying the Compatible Controller

| Identification Point | Compatible Controller | Incompatible Controller |
|---|---|---|
| Serial Number Initial on the Rating Plate |  <p>Initial letter: "A" or later (A, B, C...).</p> |  <p>Initial Letter: "0"</p> |

6 - 2 Compatibility

(1) The E3000i CONTROLLER is compatible with the following overseas safety standard.

- Safety standard in North America (UL,CSA) 
 - UL61010-1 CSA C22.2 No.61010-1
- EC Directive 
 - Low Voltage Directive IEC/EN 61010-1
 - EMC Directive EMS : EN61000-6-2
 - EMI : EN61000-6-4
 - RoHS Directive 2011/65EU, (EU) 2015/863
- United Kingdom Conformity Assessed (UKCA) marking 

6 - 3 Outside View

*Below is an outside view with Brackets (Standard Accessory) attached.

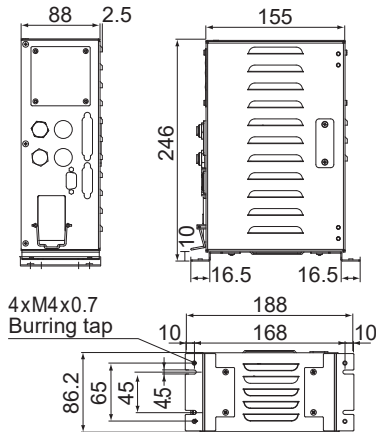

Fig. 1 Bottom Mounting

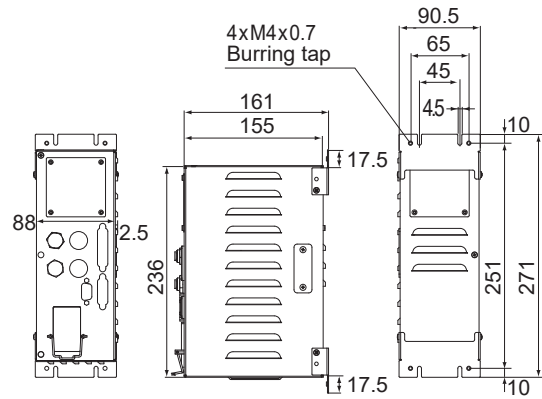

Fig. 2 Rear Mounting

*Dimensions with the horizontal bracket (optional) installed.

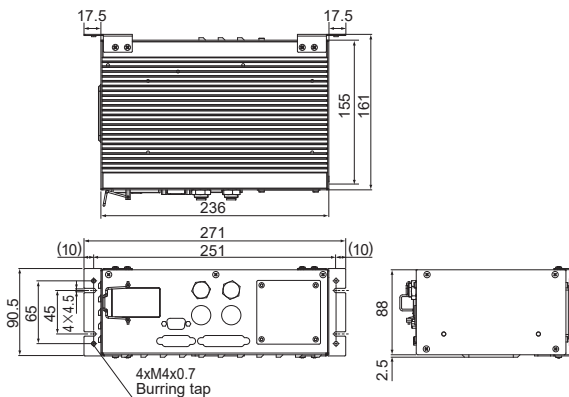

Fig. 3 Rear Mounting

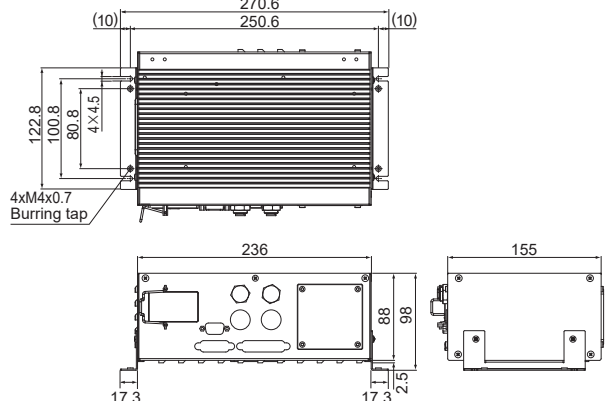

Fig. 4 Bottom Mounting

7. SYSTEM CHART

⚠ DANGER

Do not rotate the machining centers' main spindle with the HES installed.
 Rotating the machining centers' main spindle with the HES installed can cause the motor cord to become tangled and pull the CONTROLLER off its mounting.

7 - 1 Motor Speed 80,000min⁻¹ (rpm)

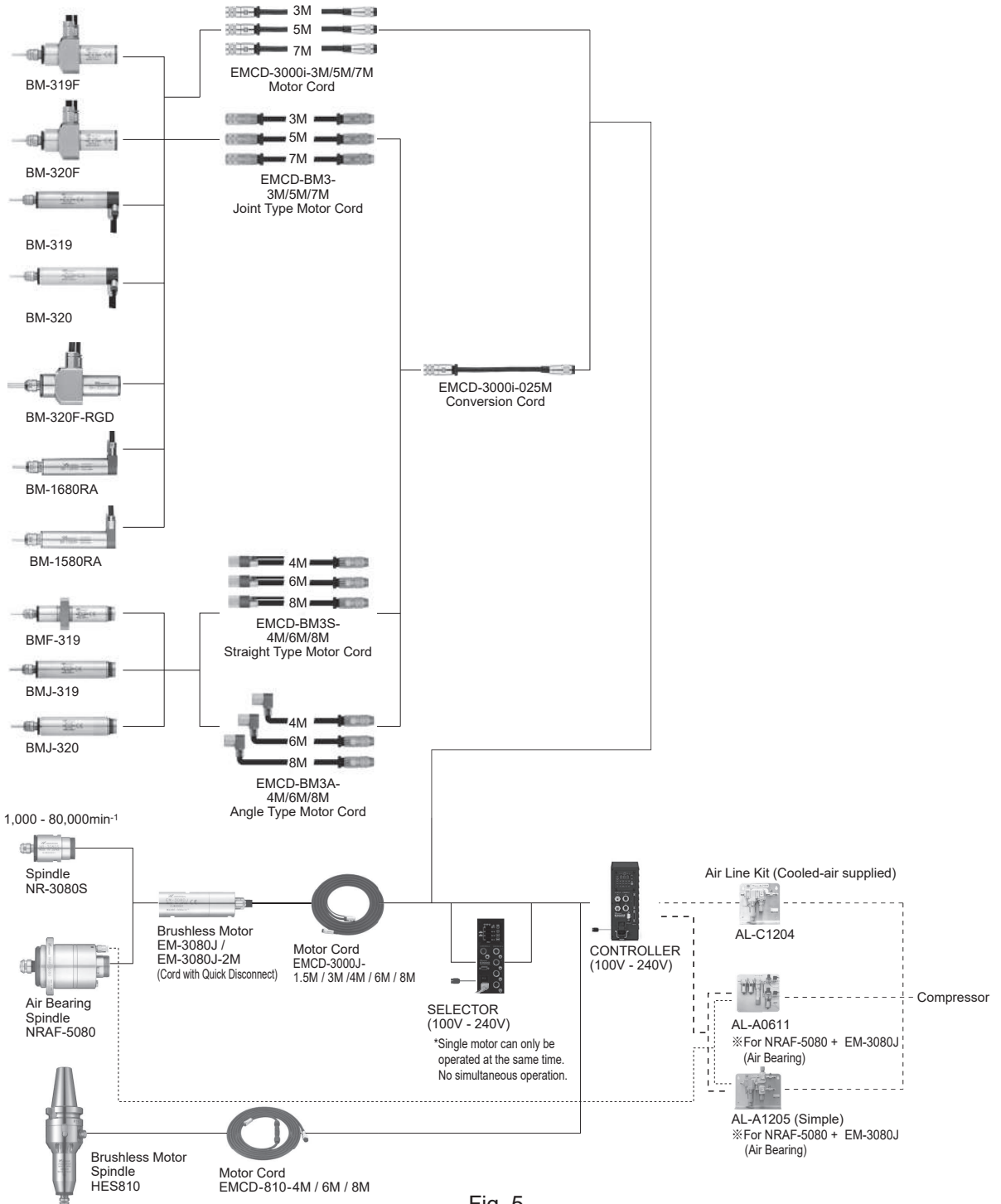

Fig. 5

7 - 2 Motor Speed 60,000min⁻¹ (rpm) / 50,000min⁻¹ (rpm) / 32,000min⁻¹ (rpm)

(1) One piece Type

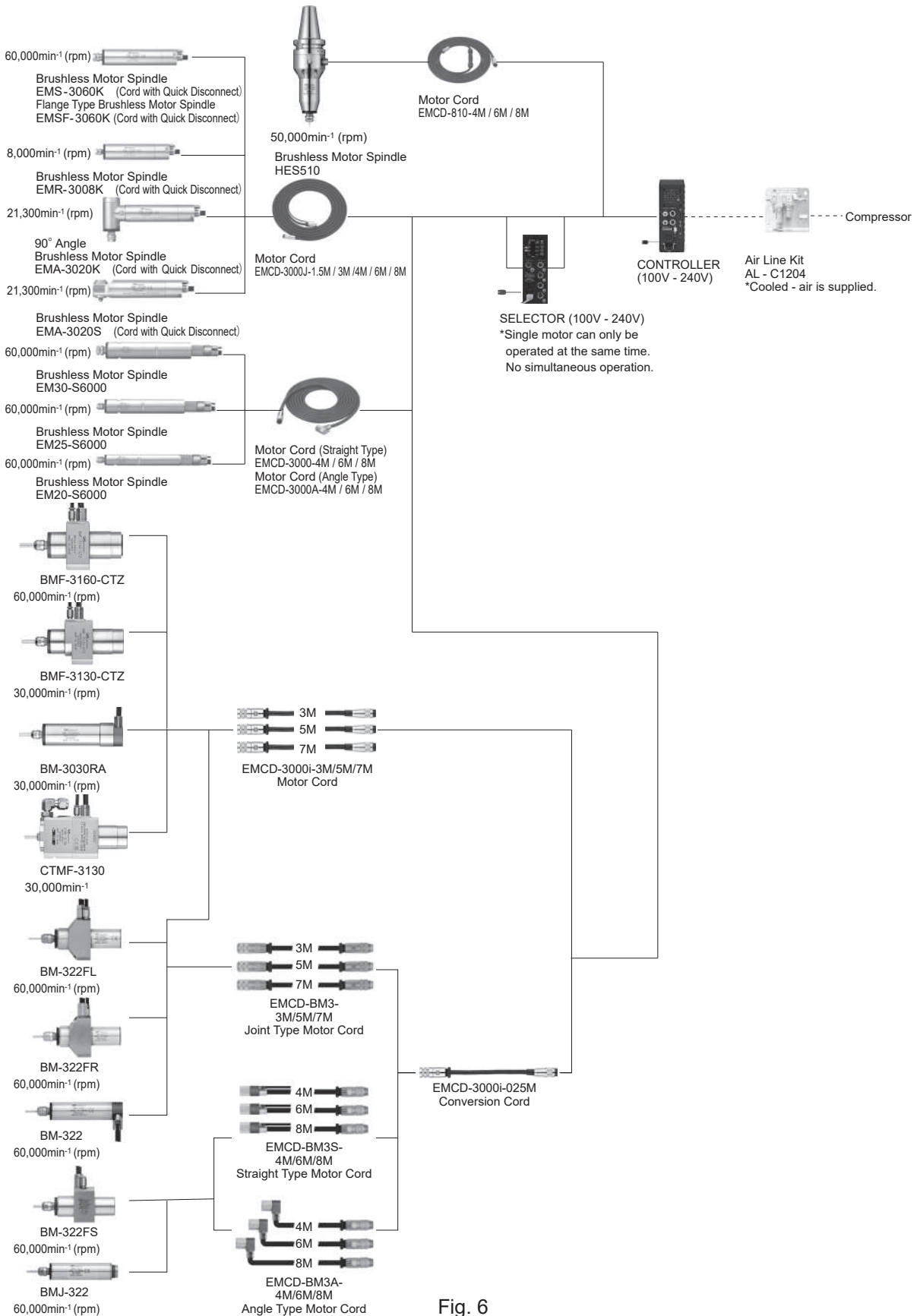
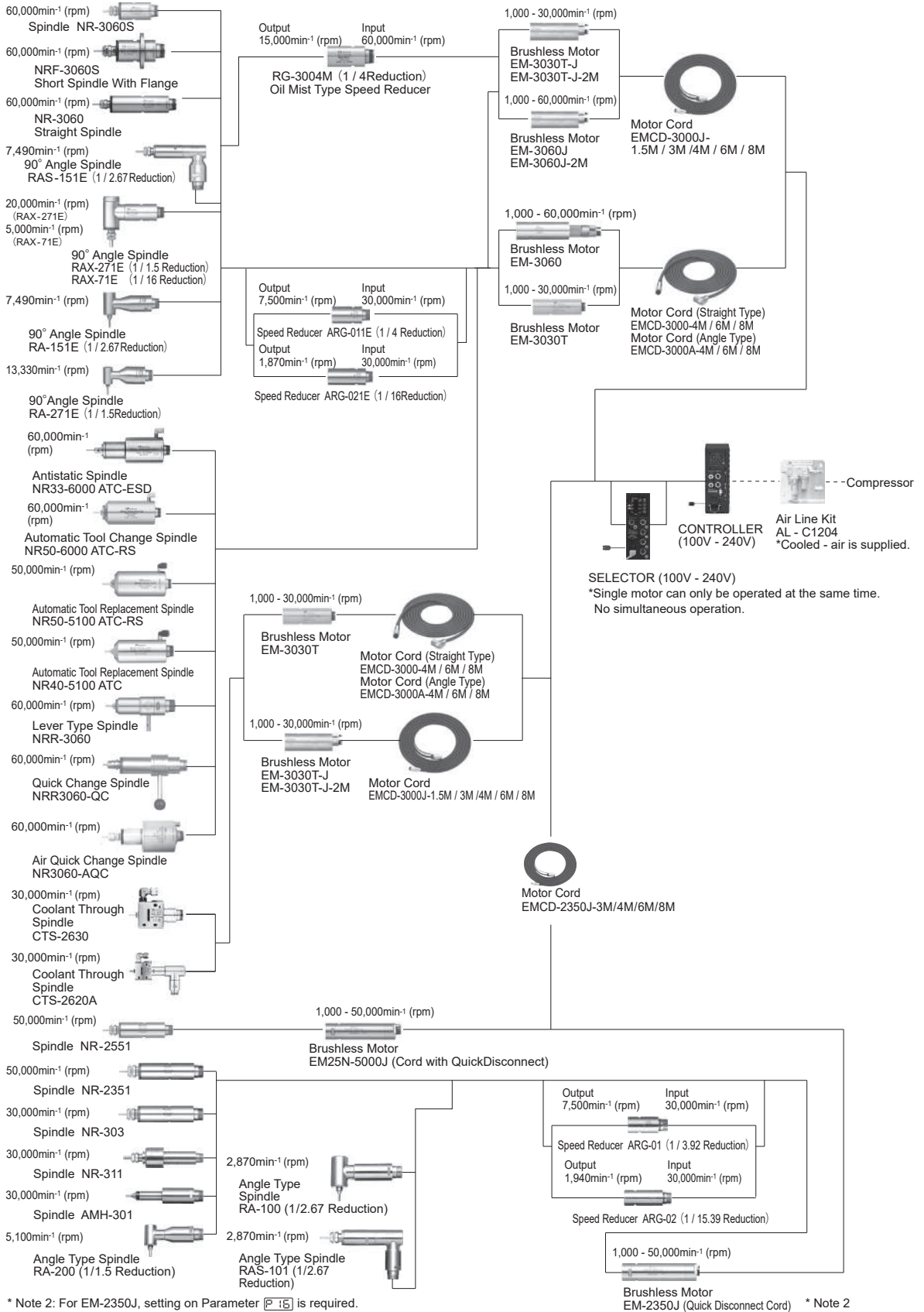

Fig. 6

(2) Separate Type



* Note 2: For EM-2350J, setting on Parameter is required.

Brushless Motor EM-2350J (Quick Disconnect Cord) * Note 2

Fig. 7

7 - 3 iSpeed5 System

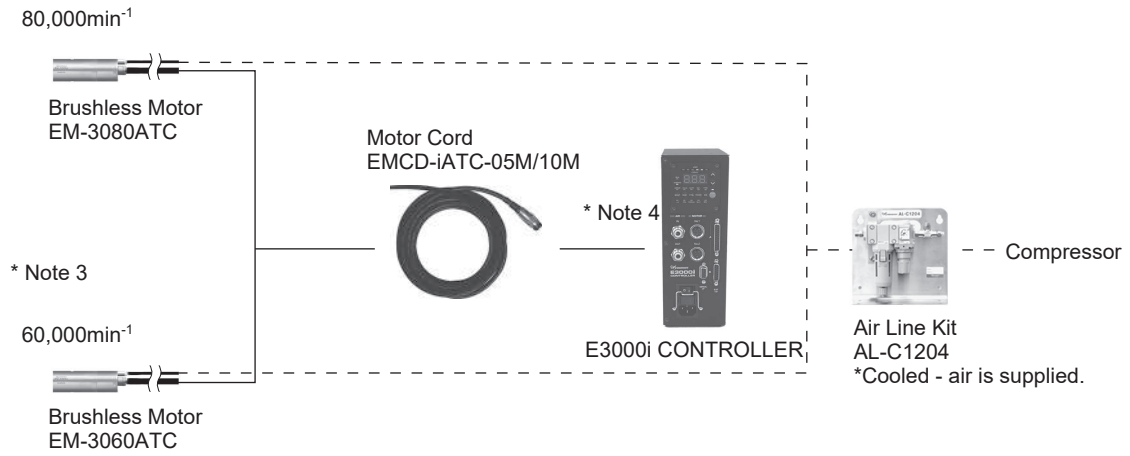

* Note 3: For the motor for iSpeed5, setting on Parameter $\boxed{P15}$ is required.

* Note 4: Motor No. 2 cannot be used.

Fig. 8

8. TORQUE CHARACTERISTICS

(1) 80,000min⁻¹ (rpm)

① EM-3080J/HES810

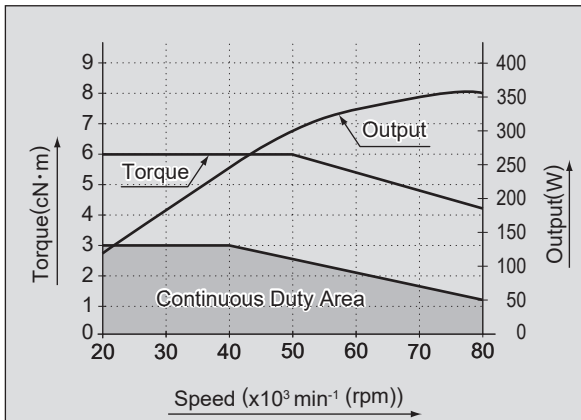

Fig. 9

② BM-319/BMJ-319/BMF-319/BM-319F/BM-320/BMJ-320/BM-320F

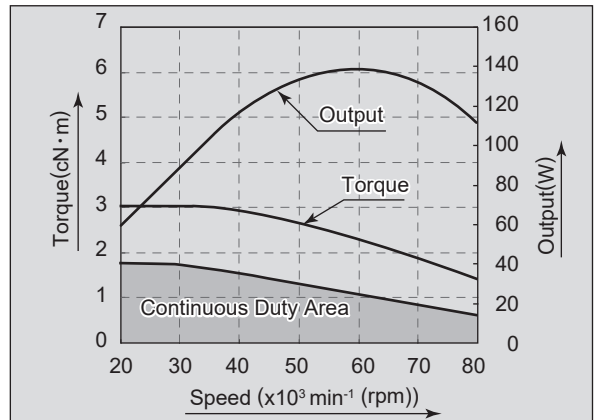

Fig. 10

③ BM-1680RA/BM-1580RA

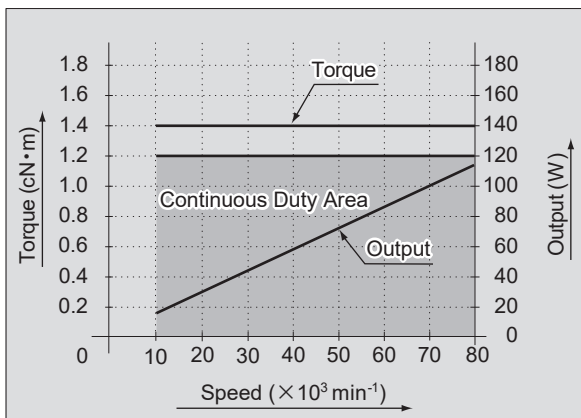

Fig. 11

(2) 60,000min⁻¹ (rpm)

① BMF-3160-CTZ/EMS-3060K/EMSF-3060K/
EMS-3060A/EM30-S6000/EM25-S6000/
EM20-S6000/EM-3060/EM-3060J

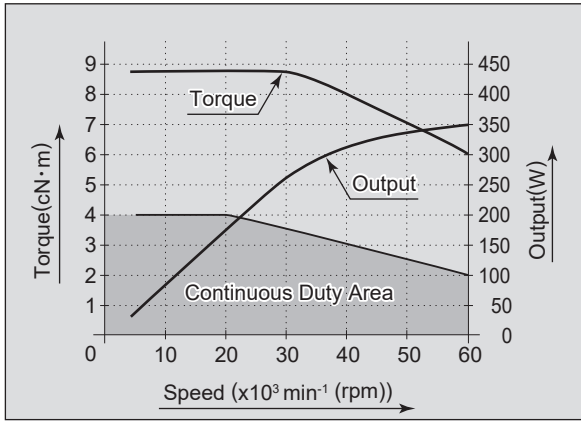

Fig. 12

② BM-322/BMJ-322/BM-322FL/BM-322FR/BM-322FS

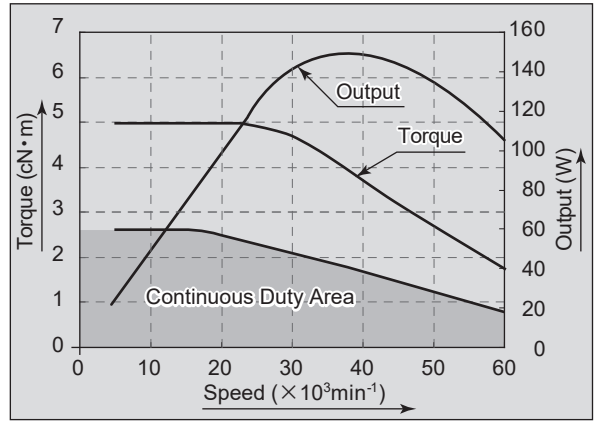

Fig. 13

(3) 50,000min⁻¹ (rpm)

① EM25N-5000

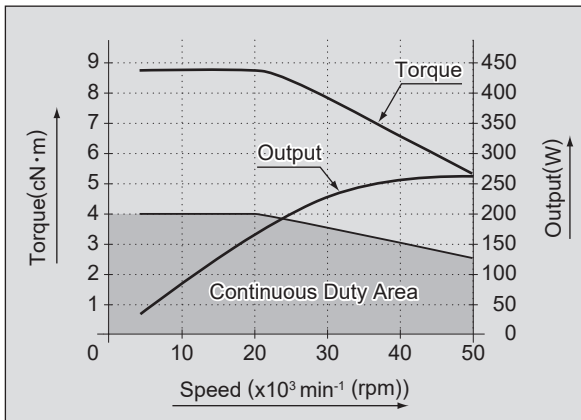

Fig. 14

② HES510

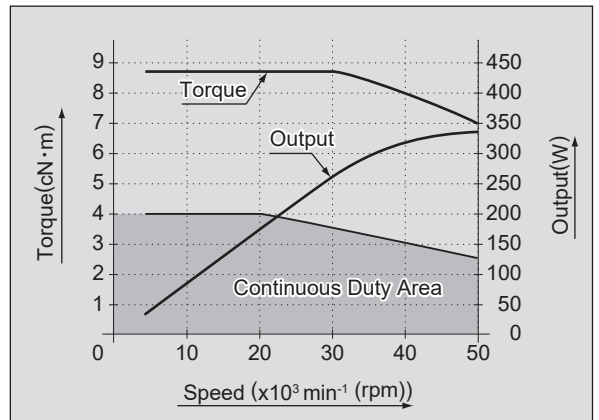

Fig. 15

③ EM-2350J

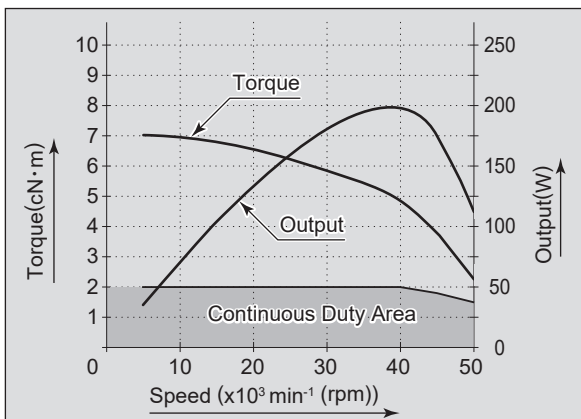

Fig. 16

(4) 32,000min⁻¹ (rpm)

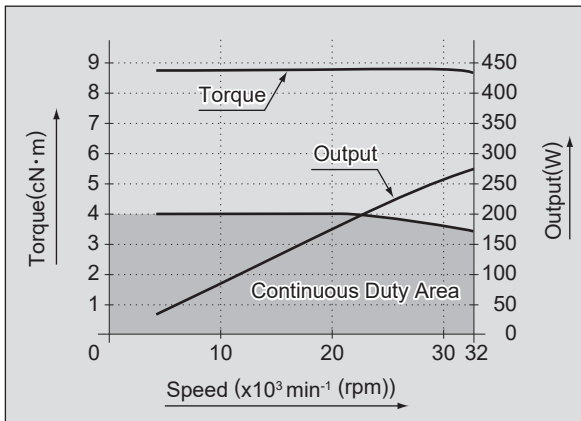

Fig. 17

(5) 30,000min⁻¹ (rpm)

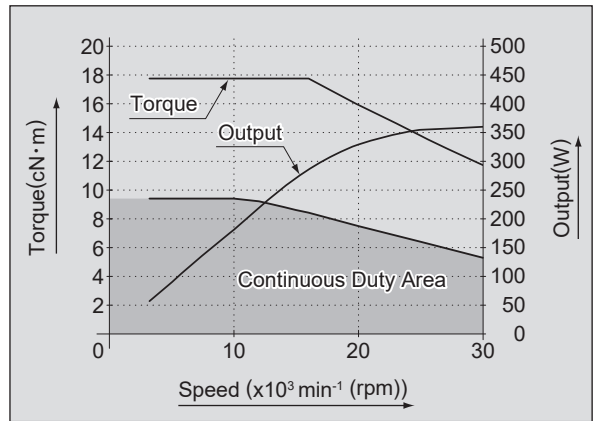

Fig. 18

9. CONTROL PANEL FEATURES

9 - 1 System

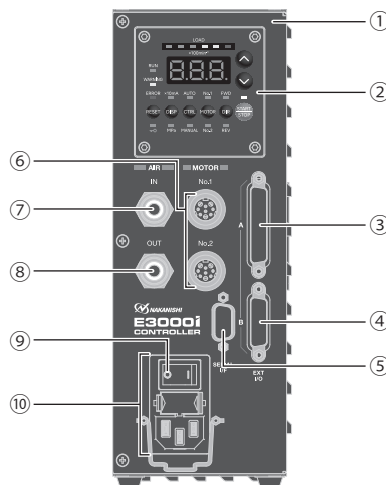

Fig. 19

① E3000i CONTROLLER

② Control Panel

Refer to "9 - 2 Control Panel Details " section.

③ Input / Output Connector A

Input / Output Connector A is for automatic control and monitoring of motor / spindle system. Refer to "18 - 1 (1) Details of External Input / Output Connector A ③ Signals " section.

Attach the provided Connector Cover A for safety and dust proofing, when not using Input / Output connector A ③ .

④ Input / Output Connector B

Connector for automatic monitoring of emergency conditions.

Refer to "18 - 2 (1) Details of External Input / Output Connector B ④ Signals " section.

Attach the provided Connector Cover B for safety and dust proofing, when not using Input / Output connector B ④ .

⑤ Serial I/F Connector

Serial I/F Connector is for the SELECTOR for Communication Cable. Refer to " 12 - 2 Connection of Communication Cable " section of the E3000 SELECTOR Operation Manual.

Attach the provided Serial I/F Connector Cover for safety and dust proofing when not using Serial I/F Connector.

CAUTION

Do not connect any device other than E3000 SELECTOR to the Serial I/F Connector of the CONTROLLER, as this will cause damage to the CONTROLLER.

⑥ Motor Connector

Connect the Motor Cord Plug of the motor spindle. Refer to "13. MOTOR CORD CONNECTION " section.

⑦ Air Input Joint

Supply clean, dry, regulated air for motor cooling. Regulate air to between 0.2 - 0.5MPa (29 - 72.5 psi).

Max. Air Consumption is 30NL/min. Air must be supplied to operate the system at maximum rpm. Refer to " 15. AIR HOSE CONNECTION AND AIR PRESSURE SETTING " section.

CAUTION

If the air pressure is too low the E3000i CONTROLLER will not operate.

⑧ Air Output Joint

Connect Air Hose to supply clean, dry, regulated air for motor and spindle cooling and purging. Refer to " 15. AIR HOSE CONNECTION AND AIR PRESSURE SETTING " section.

⑨ Main Power Switch

ON / OFF main power source. The designation " I " Indicates ON. The designation " O " Indicates OFF.

⑩ Main Power Inlet with Power Supply Fuses

Insert the Power Cord. Refer to " 12. POWER CORD CONNECTION " section.

Two fuses (T6.3AH (250V)) have been installed. Make sure the properly rated and type of fuses are used when replacements are necessary. When replacing fuse, refer to " 10. REPLACING FUSES " section.

9 - 2 Control Panel Details

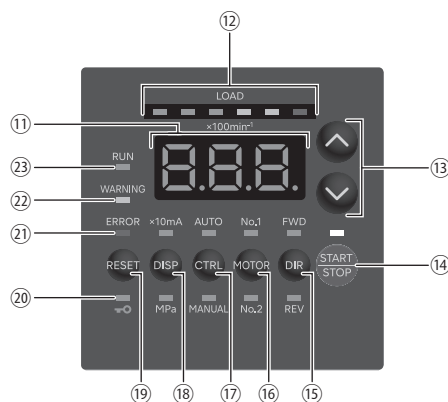

Fig. 20

⑪ Digital Speed Indicator

Preset Speed, Actual Speed, Warning and Error Codes are displayed in 3 digit format. When the motor is stopped the Preset Speed is displayed, when the motor is rotating the actual speed is displayed.

The display also displays the error codes when an error has occurred.

- ⑫ **Load Monitor LED (LOAD)**
The motor spindle load is indicated by the LED's. The 6 LED's (3 Blue, 2 Yellow and 1 Red) indicate the percentage in 6 levels against the allowable load on the CONTROLLER and motor spindle. Continuous operation is possible under a load status indicated by up to 3 blue LED's illumination. Only intermittent operation is possible under a state of overload indicated by the yellow and red LED's illumination.
- ⑬ **Motor Speed Adjustment Button (▲, ▼)**
(Manual adjustable speed control is possible. (▲ (UP) or ▼ (DOWN).)
Speed is adjustable from 1,000 - 80,000 min⁻¹ (rpm). Maximum motor speed depends on the type of motor.
- ⑭ **START / STOP Button (START / STOP)**
Starts and stops motor rotation.
- ⑮ **Rotation Direction Button (DIR)**
Right hand rotation (FWD) and left hand rotation (REV) are as viewed with the cutting tool facing the operator. With the cutting tool facing the operator right hand rotation (FWD) will be counterclockwise rotation.
- ⑯ **Motor Selection Button (MOTOR)**
Select the motor spindle to use with this button. The LED on the selected motor will illuminate when the Motor Selection Button (MOTOR) is pressed.
- ⑰ **Control button (CTRL)**
Switch the control mode to AUTO or MANUAL with this button.
MANUAL: Operate on Control Panel ② .
AUTO : Operate by input signals from an external device to the External Input / Output Connector A ③ .
- ⑱ **Display Switch Button (DISP)**
Switch the display of motor rotation speed, motor current value, and air pressure value with this button.
• When x10mA LED and MPa LED are not illuminating: Motor rotation speed is displayed.
• When x10mA LED is illuminating: Motor current value is displayed.
• When MPa LED is illuminating: Air pressure value is displayed.
However, if air pressure detection is disabled on Parameter $\boxed{P \ 9}$, or iSpeed5 motor is selected on Parameter $\boxed{P \ 15}$, "-.-" is displayed, instead of the air pressure value display.
- ⑲ **Error Reset Button (RESET)**
This switch resets the error and allows restarting of the motor spindle after an error has been corrected. Some error codes will not allow the unit to be reset until after the Main Power Switch ⑨ has been turned OFF.
- ⑳ **Key Hold Button (■)**
Press and hold the Error Reset Button ⑲ for 1 to 2 seconds to activate the key hold function, which disables button operations on the Control Panel ② . While key hold is activated, the blue LED above the ■ button illuminates. To release key hold, press and hold the Error Reset Button ⑲ for 1 to 2 seconds again.
- ㉑ **Error LED (ERROR)**
When a serious problem with the system, or continuously in a warning state this LED illuminates. The motor may shut down and the Digital Speed Indicator ⑪ will displays an error code.
- ㉒ **Warning LED (WARNING)**
The operating and working conditions of the system are constantly monitored and the Warning LED (WARNING) flashes when a hazardous condition has been detected. When a hazardous condition is detected the Warning LED (WARNING) flashes and the Digital Speed Indicator ⑪ alternates between the Warning Code and the actual or preset speed, depending on whether or not the motor/spindle is rotating or not.
- ㉓ **Rotating LED (RUN)**
When the motor is rotating this LED will illuminate.

10. REPLACING FUSES

WARNING

- Before removing the fuse holder and fuses, be sure that the Main Power Switch ⑨ is turned OFF and the Power Cord has been removed from the CONTROLLER.
- Verify type and use only following the properly rated and type of fuse.
Specified fuses : T6.3AH (250V) 021506.3MXP (Littelfuse, Inc.)
- * Failure to use the proper type and rated fuse will result in fire, injury, electric shock and / or product damage.

- (1) Push on the clips on the right and left of the fuse holder and remove the fuse holder block.
- (2) Remove the bad fuse or fuses and replace with the proper type and rating of fuse by the input voltage being used.
- (3) Replace the fuse holder containing the fuses into the Main Power Inlet with Power Supply Fuses ⑩ and make sure it snaps in place.

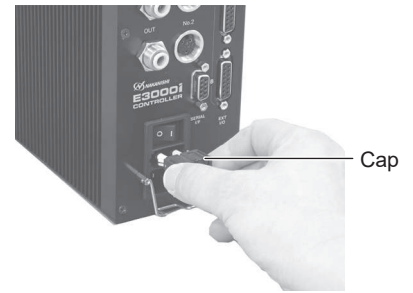

Fig. 21

11. BRACKET AND RUBBER PAD INSTALLATION

11 - 1 Installation of the Bracket



CAUTION

- If there is a possibility for the CONTROLLER to move from its mounting location, for safety, be sure to secure it with the brackets provided.
- When installing the CONTROLLER, be sure to place air vents downward, away from debris. Protect the CONTROLLER (air vents and other connector) from cutting oil, mist oil, powder dust, other contaminants that can buildup heat and damage the internal components of the CONTROLLER.
- When installing the optional DL-Type bracket, remove the rubber pads.

- 2 types of Mounting Brackets are provided for both Bottom mounting and Rear mounting.
- The Bracket can be installed on the " Bottom Mounting (Fig. 22) " and " Rear Mounting (Fig. 23) " of the CONTROLLER.

(1) Attach the Installation Brackets (2pcs.) using the provided mounting screws. (4pcs.)

(2) Attach the CONTROLLER (Bracket's Slotted Area) to the machine using the provided mounting screws.

Bottom Mounting



Fig. 22

Rear Mounting

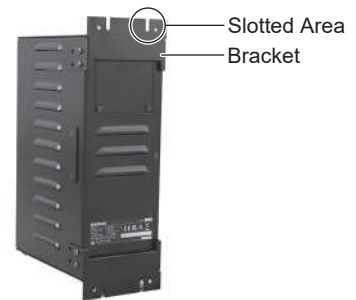

Fig. 23

Rear Mounting

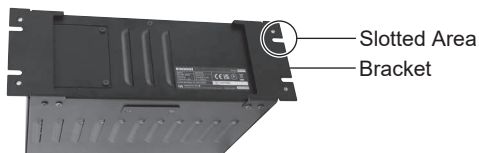

Fig. 24

Bottom Mounting

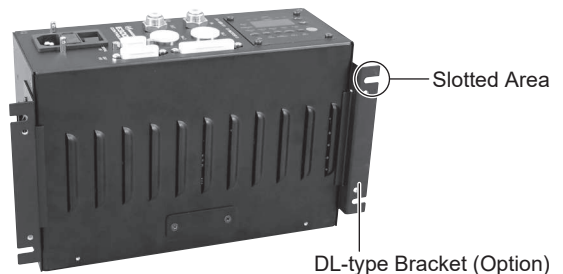

Fig. 25

11 - 2 Installation of the Rubber Pad

⚠ Caution for when installing the CONTROLLER horizontally

- When installing the CONTROLLER, be sure to place the air vents downward, away from debris (Fig. 26). Protect the CONTROLLER (air vents and other connector) from cutting oil, mist oil, powder dust, other contaminants that can buildup heat and damage the internal components.
- When rotating the direction of setting Control Panel ②, ensure that the Main Power Switch ⑨ is turned OFF and the Power Cord has been removed from the CONTROLLER.

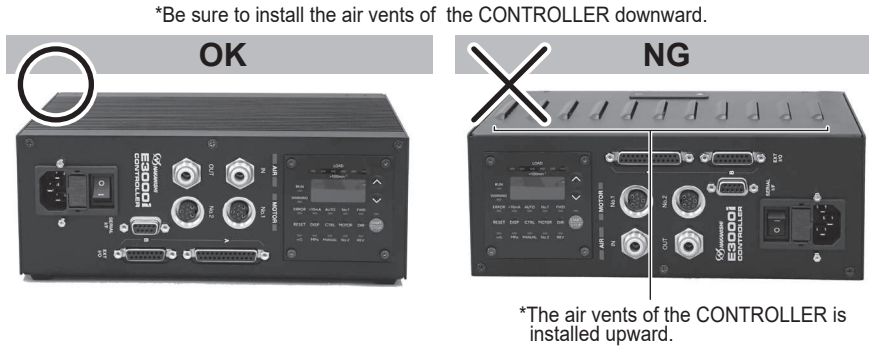

Fig. 26

When placing the CONTROLLER horizontally, the Rubber Pads (Provided) must be installed on the side of the air vents. The Control Panel ② can be rotated 90° from the original position. (Refer to " 16. CHANGING THE CONTROL PANEL " section.) To rotate, remove the 4 Control Panel Mounting Screw attached to Control Panel ②. Change position of the Control panel ② and re-install the 4 Control Panel Mounting Screws.



Fig. 27



Fig. 28

11 - 3 Proper Clearance

⚠ CAUTION

When installing 2 or more CONTROLLERS in the machine cabinet, make sure to check that each unit has the proper clearance on all sides for sufficient air flow. Insufficient clearance will cause heat damage to the CONTROLLER and SELECTORS.

When installing the CONTROLLER and SELECTOR, refer to Fig. 29 and Fig. 30.

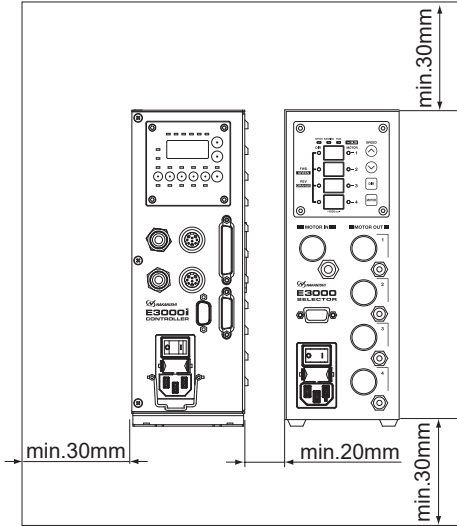

Fig. 29 Rear Mounting

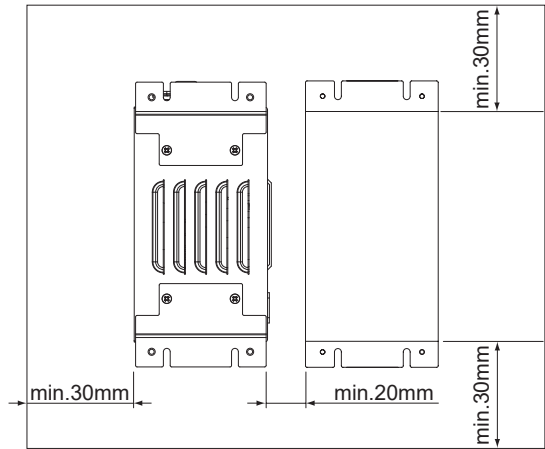

Fig. 30 Bottom Mounting

12. POWER CORD CONNECTION

⚠ WARNING

Only use grounded power sources. Using a non-specified Power Cord, the risk of fire by overheating of the cord is possible.

⚠ CAUTION

- Reduce the risk of unintentional starting. Make sure the Main Power Switch ⑨ is in the OFF position before connecting the CONTROLLER or plugging the system in.
- When installing the CONTROLLER, provide space of approximately 10cm around the CONTROLLER for easy access to the air inlet and the Power Cord Plug.

- (1) Insert the supplied Power Cord Hook ⑳ into the Power Cord Hook Fixing Bar ㉑ located on the front side of the Control Unit.
- (2) Insert the Power Cord into the Main Power inlet with Power Supply Fuses of the Control Unit. (Refer to Fig. 32.)
- (3) Fix the Power Cord with the Power Cord Hook ㉒. (Refer to Fig. 33.)

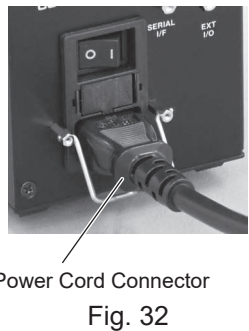
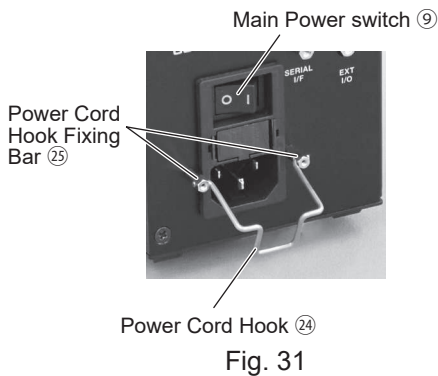

13. MOTOR CORD CONNECTION

⚠ CAUTION

Before connecting to the Motor Cord Plug, make sure the Main Power Switch ⑨ is turned OFF. If the Main Power Switch ⑨ is turned ON while connecting the Motor Cord Plug, damage may occur to the CONTROLLER.

- (1) Ensure the Alignment Pin is located upward (12 o'clock position).
- (2) Carefully insert the Alignment Pin into the Alignment Hole and push straight into the Motor Connector ⑥ on the front of the CONTROLLER.
- (3) Tighten the Connector Nut.

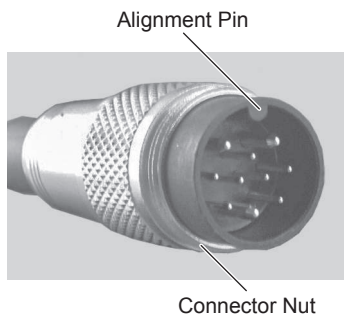

Fig. 34

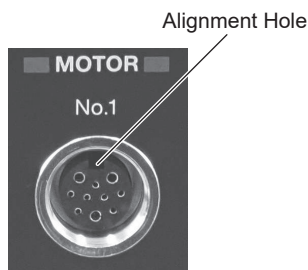

Fig. 35

14. MOTOR CURRENT DISPLAY FUNCTION AND TIGHTENING WHEN CLAMPING

14 - 1 Motor Current Display

The Motor Current Display function displays load on the Motor Spindle in current value (x10mA). To display the motor current value, refer to "9 - 2 Control Panel Details ⑱". This display allows you to confirm processing load and tightness when fixing the Motor Spindle in value.

14 - 2 Tightening When Clamping

Use the motor current display function to adjust the tightness. As a guide, perform tightening so that the displayed current value is as follows. The values below are the current of no-load rotation after tightening, with respect to the current value of no-load rotation at the maximum rotation speed before tightening.

- BM-3**/BMJ-3** : +1(+10mA) or less
- EM-**** (motor)/EM*-**** (one piece type) : +5(+50mA) or less

15. AIR HOSE CONNECTION AND AIR PRESSURE SETTING

15 - 1 Air Hose Connection and Air Pressure Setting

⚠ CAUTION

When not using NAKANISHI Air Line Kit, make sure that the incoming air supply is dry, clean and properly regulated.

- (1) Insert the provided ϕ 6mm Air Hose with Filter from the Air Line Kit AL - C1204 into the Air Input Joint ⑦ on the front of the CONTROLLER.
- (2) Insert one end of the provided ϕ 4mm cooling Air Hose into the back of the motor.
- (3) Insert the other end of the ϕ 4mm cooling Air Hose into the Air Output Joint ⑧ on the front of the CONTROLLER. To connect one motor spindle, use the Reducer (ϕ 6mm - ϕ 4mm Conversion Adapter). To connect two motor spindles, use the provided branch adapter.
- (4) Regulate air pressure. Set air pressure as follows. (Refer to Table. 3 in the " 15 - 2 Setting Air Pressure " section.

Setting parameter $\boxed{P\ 9}$ (refer to "20 - 4 ⑨ $\boxed{P\ 9}$ Selection of Air Input Monitoring Override" section), allows the motor to run at 30,000min⁻¹ (rpm) without motor cooling.

Running the motor and spindle without cooling can cause premature failure due to high temperatures.

Limit the usage of parameter to "20-4 ⑨ $\boxed{P\ 9}$ Selection of Air Input Monitoring Override" (startup motor without supplying cooling air) to only when supply cooling air is not suitable or available.

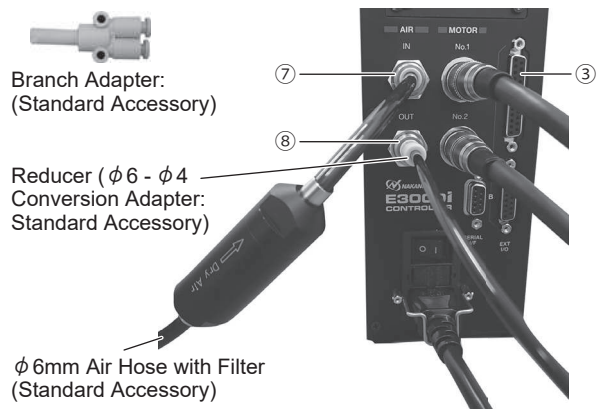

Fig. 36

15 - 2 Setting Air Pressure

The necessary air supply pressure differs depending on the number of connected motors to use and the air hose length. Check the number of connected motors and the length of the hose, and set the air pressure as indicated in tables 3 to 9. " Hose length " means the total length of the air hose supplied with a Cord with Quick Disconnect and the air hose supplied with a motor cord.

Table. 3

E3000i series motor spindle (other than BM-1680RA/BM-1580RA)

| Hose length (m) | | 3.5 | 5.5 | 7.5 |
|---------------------------------------|--------------------|-----|------|-----|
| When one motor spindle is connected | Air pressure (MPa) | 0.2 | 0.25 | 0.3 |
| When two motor spindles are connected | | 0.3 | 0.35 | 0.4 |

Table. 4

E3000i series motor spindle (BM-1680RA/BM-1580RA)

| | | | | |
|---------------------------------------|--------------------|------|------|------|
| Hose length (m) | | 3.5 | 5.5 | 7.5 |
| When one motor spindle is connected | Air pressure (MPa) | 0.25 | 0.30 | 0.35 |
| When two motor spindles are connected | | | | |

Table. 5

E2000 series motor spindle

| | | | | |
|---------------------------------------|--------------------|------|------|------|
| Hose length (m) | | 4.0 | 6.0 | 8.0 |
| When one motor spindle is connected | Air pressure (MPa) | 0.30 | 0.35 | 0.40 |
| When two motor spindles are connected | | | | |

Table. 6

E3000 series motor spindle (other than HES series)

| | | | | | | |
|---------------------------------------|--------------------|------|------|------|------|------|
| Hose length (m) | | 3.3 | 4.0 | 5.0 | 6.0 | 8.0 |
| When one motor spindle is connected | Air pressure (MPa) | 0.30 | 0.35 | 0.40 | 0.45 | 0.45 |
| When two motor spindles are connected | | | | | | |

Table. 7

E3000 series motor spindle (HES series)

| | | | | |
|-------------------------------------|--------------------|------|-----|-----|
| Hose length (m) | | 4.0 | 6.0 | 8.0 |
| When one motor spindle is connected | Air pressure (MPa) | 0.25 | 0.3 | |

Table. 8

iSpeed3 series motor spindle

| | | | | | | | |
|---------------------------------------|--------------------|-----|------|-----|-----|-----|-----|
| Hose length (m) | | 3.5 | 4.0 | 5.5 | 6.0 | 7.5 | 8.0 |
| When one motor spindle is connected | Air pressure (MPa) | 0.2 | 0.25 | 0.3 | 0.3 | 0.3 | 0.3 |
| When two motor spindles are connected | | | | | | | |

Table. 9

Combination of motor spindles of different series

| | | | | |
|---|--------------------|------------|------------|------------|
| Hose length (m) | | 3.5 to 4.0 | 5.5 to 6.0 | 7.5 to 8.0 |
| When two motor spindles of different series are connected | Air pressure (MPa) | 0.30 | 0.35 | 0.40 |

**CAUTION**

- The cooling air also provides air purge protection to the motor spindle. If the Main Power Switch ⑨ is turned OFF, the cooling air will continue to flow. When using the CONTROLLER and SELECTOR without supplying cooling air, change setting parameter "20 - 4 ⑨  Selection of Air Input Monitoring Override " to ON. Never spray coolant directly on the spindle body without an air purge.
- When using the SELECTOR, do not use Air input Joint ⑦ nor Air Output Joint ⑧ of the CONTROLLER. Install the provided Air Plug ((ϕ 6) for air stop) for safety and dust proofing to Air Input Joint ⑦ and Air Output Joint ⑧. The Air Input can be directly connected to the SELECTOR.
- Do not make any sharp bends in the air hose, or pull on the hose as this can cause the hose to break, cut off the air supply or weaken the hose over time resulting in deterioration of the motor and spindle.
- Attach the provided Connector Cover for safety and dust proofing when not using the External Input / Output Connector A ③, B ④, or Serial I/F Connector ⑤ of the CONTROLLER.
- Never supply over regulated air pressure. There is a possibility to damage to the air detection sensor inside the CONTROLLER.
- The air detect function within the CONTROLLER detects air input supply only. If the Air Out hose is damaged from the CONTROLLER, it will not be able to detect the lack of cooling and purging air to the motor spindle.

16. CHANGING THE CONTROL PANEL

WARNING

Make sure the input power supply is OFF before rotating the direction of setting Control Panel. If the incoming power supply is ON, it may cause electric shock or damage to the CONTROLLER.

The position of the Control Panel can be changed from the front to rear of the CONTROLLER.

- (1) Remove the 4 screws that affix the Control Panel and pull the Control Panel gently from the CONTROLLER (Fig. 37).

Remove the connector from rear of the Control Panel (Fig. 37).

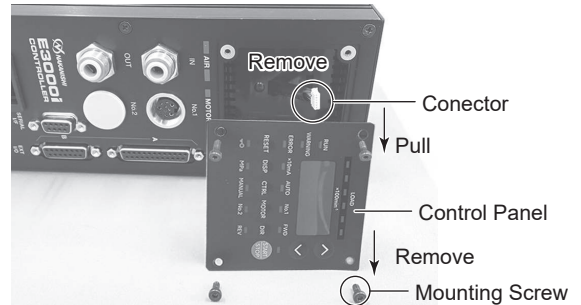

Fig. 37

- (2) Remove the screw from the Plate and pull the Plate from the CONTROLLER (Fig. 38).

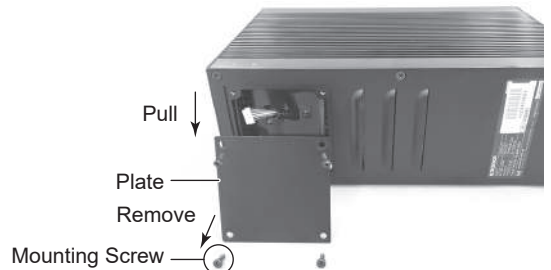

Fig. 38

- (3) Connect the connector inside the CONTROLLER to the connector of the rear of the Control Panel. (Fig. 39).
- (4) Re-attach the Control Panel using the 4 mounting screws (Fig. 39).

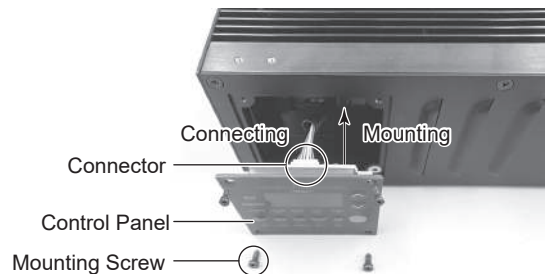

Fig. 39

- (5) Mounting the Plate using the 4 mounting screws. (Fig. 40).

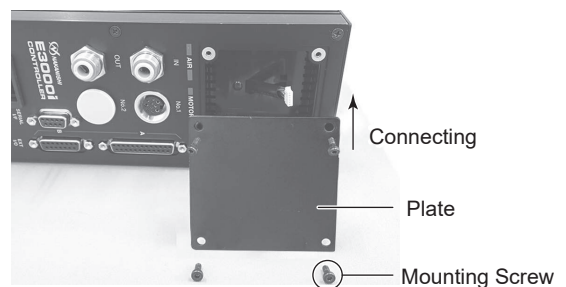

Fig. 40

17. OPERATION PROCEDURES

17 - 1 Select Control Mode (MANUAL / AUTO). (Select the Control Button (CTRL) ⑰ of the Fig. 41.)

- (1) Using the Control Button (CTRL) ⑰ you can select between Manual (Front panel control) or Auto (External Signal Source) modes. External Signal Source can be used to control Motor Start / Stop, Rotation Direction, Motor Speed etc. From an external control source (CNC).
- (2) When operating using the button on the Control Panel ②, push the Control Button (CTRL) ⑰ to select MANUAL. When operating from an External Signal Source, push the Control Button (CTRL) ⑰ to select AUTO.

MANUAL Mode : Controlled by Control Panel ② .

AUTO Mode : Controlled by Input / Output Connector A ③ and from an External Signal Source.

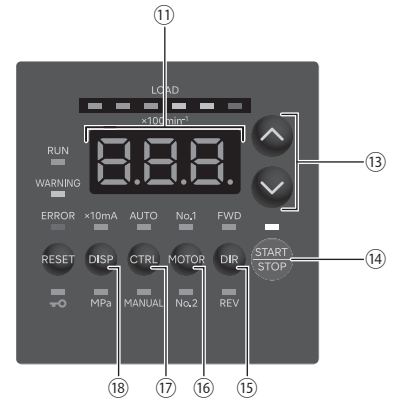

Fig. 41

17 - 2 Setting Motor Rotating Direction, Motor Selection (No. 1 / No. 2), Motor Start / Stop, Motor Speed

17 - 2 - 1 Manual Mode Operation

- (1) Set Motor Rotating Direction (Set the Rotation Direction Button (DIR) ⑮ of the Fig. 41.)
Push the Rotation Direction Button (DIR) ⑮ .
Select FWD : Clockwise rotation.
Select REV : Counterclockwise rotation.
With the cutting tool facing the operator (FWD) will be counterclockwise rotation.
- (2) Select the motor (Use the Motor Selection Button (MOTOR) ⑯ . of Fig. 41.)
Push the Motor Selection Button (MOTOR) ⑯ .
If you select Motor No. 1, the motor connected to Motor Connector No. 1 ⑥ will rotate. If you select Motor No. 2, the motor connected to Motor Connector No. 2 ⑥ will rotate.
- (3) Set 500 min^{-1} (rpm) Centering Rotation (Set the Motor Speed Adjustment Button (\blacktriangle , \blacktriangledown) ⑬ of the Fig. 41.)

CAUTION

Never attempt to cut while rotating in Centering Mode.

- To select 5 (500 min^{-1} (rpm)), push the Motor Speed Adjustment Button (\blacktriangle , \blacktriangledown) ⑬ . When controlling motor speed from 1,000 min^{-1} (rpm) to 500 min^{-1} (rpm) or from 500 min^{-1} (rpm) to 1,000 min^{-1} (rpm), stop the motor spindle prior to changing speed.
- (4) Motor Start / Stop (Motor Start / Stop by pushing the START / STOP Button (START / STOP) ⑭ of the Fig. 41.)
The motor spindle will start and the LED will illuminate.
Push START / STOP Button (START / STOP) ⑭ again and the motor will stop and the LED will go out.
 - (5) Setting Motor Speed (Set the Motor Speed Adjustment Button (\blacktriangle , \blacktriangledown) ⑬ of the Fig. 41.)
Set the speed by pushing the Motor Speed Adjustment Button (\blacktriangle , \blacktriangledown) ⑬ .
 - Motor Speed Range is 1,000 - 80,000 min^{-1} (rpm).
 - The motor speed is displayed in 200 min^{-1} (rpm) increments. 800 equals 80,000 min^{-1} (rpm).

17 - 2 - 2 Setting Auto Mode

Use the Input / Output Connector A ③ to input control signals to the CONTROLLER.

(1) Set motor Rotating Direction

Input the " Rotating Direction Setting (Pin No. 2 : DIR_IN) "

Clockwise rotation is ' OFF (Open) ' (" FWD ", LED will illuminate)

Counterclockwise rotation is ' ON (Closed) ' (" REV ", LED will illuminate)

With the cutting tool facing the operator (FWD) will be counterclockwise rotation.

(2) Select the Motor

Select the motor by using the Motor Selection Signal (Pin No. 9 : MT_SEL). To select Motor No. 1, set the signal to OFF (Open). To select Motor No. 2, set the signal to ON (Closed).

After selecting the motor, the No.1 or No.2 LED illuminates according to the setting.

(3) Set 500 min⁻¹ (rpm) Centering Rotation

⚠ CAUTION

Never attempt to cut while rotating in centering mode.

Input the " Rotates Motor at " Centering " speed (Pin No.16 : 500 min⁻¹ (rpm)) "

When using the Centering Mode : ' ON (Closed) '

(4) Motor Start / Stop

Input the " Rotate Command (Pin No. 14 : START) "

Motor rotating is ' ON (Closed) '. When startup, START LED (RUN) of the CONTROLLER will light and motor will rotate.

(5) Setting the Motor Speed

• Motor Speed Range is 1,000 - 80,000 min⁻¹ (rpm). Maximum motor speed depends on motor and spindle model (speed setting step : 200min⁻¹).

Setting parameter $\boxed{P \ 2}$ to ON allows the motor speed to be adjusted in Auto Mode using the Motor Speed Adjustment Button (\blacktriangle , \blacktriangledown) ③ of the Fig. 41.

(Refer to " 20 - 4 ② $\boxed{P \ 2}$ Setting AUTO Mode for Motor Speed Control " section.)

Rotational speed can be set by the using one of the following 3 methods.

① Setting by Analog signal

Input the " Motor Speed Control Voltage (Pin No. 22 : VR2, Pin No. 23 : VR1) ". Refer to " 18 - 1 (3) ④ Motor Speed Control Signal " section.

When using the motor with specification of 80,000min⁻¹ (rpm), set parameter $\boxed{P \ 10}$ of the CONTROLLER. This will change the Motor Speed Characteristics of the motor speed and Speed Control Voltage Signal characteristics. (Refer to " 20 - 4 ⑩ $\boxed{P \ 10}$ Selection of Motor Speed Control Voltage / DC+10V Signal Method " section.)

② Setting by Pulse Signal

(Set parameter $\boxed{P \ 7}$ of the CONTROLLER. (Refer to " 20 - 4 ⑦ $\boxed{P \ 7}$ Selection of External Speed Control Mode " section.)

Input the " Count Pulse Signal for Setting Motor Speed (Pin No. 3 : CNT_IN) " and " UP / DOWN Signal for Setting Motor Speed (Pin No. 15 : UD_IN) "

One pulse will increase or decrease 200min⁻¹ (rpm) (changeable to 1,000min⁻¹ (rpm) on " 20 - 4 ⑱ $\boxed{P \ 18}$ Setting Weight of Count Pulse for Speed Setting ") in Spindle Speed. Counted on the leading edge of the signal.

" UP / DOWN Signal for Setting Motor Speed (Pin No. 15 : UD_IN) " is ' ON (Close) ' : increases speed, ' OFF (Open) ' : decreases speed.

③ Set by the Speed Point Signal

(Set parameter $\text{P} \begin{matrix} \square \\ \square \end{matrix}$. (Refer to " 20 - 4 ⑦ $\text{P} \begin{matrix} \square \\ \square \end{matrix}$ Selection of External Speed Control Mode " section.)

CAUTION

When connecting the CONTROLLER to the SELECTOR, setting the Speed Point Signal is not possible.

Select the Speed Point (U1 - U4) by combination of " Speed Point Select 0 (Pin No. 17 : SEL0) " and " Speed Point Select 1 (Pin No. 5 : SEL1) ".

Set the Motor Rotation Speed.

Select the Speed Point (U1 - U4) by the signal combination in Table. 10

Table. 10

| Speed Point | SEL1 (Pin No. 5) | SEL0 (Pin No. 17) |
|-------------|------------------|-------------------|
| U1 | OFF (Open) | OFF (Open) |
| U2 | OFF (Open) | ON (Closed) |
| U3 | ON (Closed) | OFF (Open) |
| U4 | ON (Closed) | ON (Closed) |

(6) Resetting System after Error Codes

Releasing Error Code by The " Error Release (Pin No. 4 : RESET) ". Switch the signal on " Error Release (Pin No. 4 : RESET) " of Input / Output Connector A ③ ' OFF (Open) ' → ' ON (Closed) ' → ' OFF (Open) ' .

Error Signal will not be released until cause of the error has been removed.

Refer to " 19 - 3 Resetting System after Error Codes " section.

(7) Set Motor Selection (When connecting the SELECTOR to the CONTROLLER.)

After connecting a CONTROLLER to a SELECTOR, 4 motors can be selected by SEL0 and SEL1 combination. (Refer to Table. 11.)

Table. 11

| Select Motor | SEL1 (Pin No.5) | SEL0 (Pin No.17) |
|--------------|-----------------|------------------|
| Motor 1 | OFF (Open) | OFF (Open) |
| Motor 2 | OFF (Open) | ON (Closed) |
| Motor 3 | ON (Closed) | OFF (Open) |
| Motor 4 | ON (Closed) | ON (Closed) |

18. EXTERNAL INPUT / OUTPUT CONNECTOR

18 - 1 External Input / Output Connector A ③

(1) Details of External Input / Output Connector A ③ Signals

WARNING

- **DO NOT** connect any circuit other than SELV (Safety Extra Low Voltage) to the External Input / Output Connector A ③ of the CONTROLLER. This will cause I / O board damage in the CONTROLLER.
- Do not supply over voltage or over current into the input / output circuit. Always install a LOAD (resistor) to the output circuit to eliminate the chance of damage to the CONTROLLER.

Table. 12

| Pin No. | Code | Function | Input / Output | Description | |
|---------|--------|--|----------------|---|--|
| 1 | COM_1 | External Power source for External input | Input | DC0V or DC+24V | Power source to be used for External Inputs Signals. |
| 2 | DIR_IN | Rotating Direction Setting | Input | ' OFF (Open) ' : FWD ' ON (Closed) ' : REV | Controls the rotational direction of the motor spindle. Setting parameter $\left[\begin{array}{c} P \\ 18 \end{array} \right]$, can start ccw rotation. (Refer to " 20 - 4 ⑧ $\left[\begin{array}{c} P \\ 18 \end{array} \right]$ Selection of External Motor Start Signal Control Mode " section.) |
| 3 | CNT_IN | Count Pulse Signal for Setting Motor Speed | Input | ' OFF (Open) ' → ' ON (Closed) ' | One pulse will increase or decrease 200min ⁻¹ (rpm) (changeable to 1,000min ⁻¹ (rpm) on Parameter $\left[\begin{array}{c} P \\ 19 \end{array} \right]$) in Spindle Speed depending on parameter $\left[\begin{array}{c} P \\ 17 \end{array} \right]$ setting. (Refer to " 20 - 4 ⑦ $\left[\begin{array}{c} P \\ 17 \end{array} \right]$ Selection of External Speed Control Mode " section.) |
| 4 | RESET | Error Release | Input | ' ON (Closed) ' → ' OFF (Open) ' | Error Code can be released and the system restarted by toggling this signal ON and OFF. Error will not be released until cause of the error has been removed. |
| 5 | SEL1 | Motor Select 1 | Input | — | Use when selecting motor, after connecting CONTROLLER to the SELECTOR. 4 motors can be selected by SEL0 and SEL1 combination. Refer to " 17 - 2 - 2 (7) Set Motor Selection Table. 11.") |
| | | Speed Point Select 1 | | | When only using CONTROLLER, Speed Point Signal can be selected. Speed Point (U1 - U4) can be selected by SEL0 and SEL1 signal combination. Refer to " 17 - 2 - 2 (5) ③ Set by the Speed Point Signal Table. 10" section. Need to set parameter $\left[\begin{array}{c} P \\ 17 \end{array} \right]$. (Refer to " 20 - 4 ⑦ $\left[\begin{array}{c} P \\ 17 \end{array} \right]$ Selection of External Speed Control Mode " section.) |
| 6 | RUN | Rotating | Output | ' OFF (Open) ' : Stop ' ON (Closed) ' : Rotating | Output shows that the motor is rotating. |
| | | Stopped | | ' OFF (Open) ' : Rotating ' ON (Closed) ' : Stop | Output shows that the motor is stopped when Parameter $\left[\begin{array}{c} P \\ 12 \end{array} \right]$ is set ON. |

| Pin No. | Code | Function | Input / Output | Description | |
|---------|----------------------------|---|----------------|---|--|
| 7 | DIR_OUT | Rotating Direction | | ' OFF (Open) ' : FWD ' ON (Closed) ' : REV | Indicates the set rotation direction. Setting on Parameter $\boxed{P \ 1 \ 3}$ is required. (Refer to " 20 - 4 \textcircled{B} $\boxed{P \ 1 \ 3}$ Function Selection of Pin No. 7 of the External Input / Output Connector A $\textcircled{3}$ " section.) |
| | SEL_MT | Selected Motor | Output | ' OFF (Open) ' : MOTOR1 ' ON (Closed) ' : MOTOR2 | Output shows whether Motor No.1 or Motor No. 2 is selected. Setting on Parameter $\boxed{P \ 1 \ 3}$ is required. (Refer to " 20 - 4 \textcircled{B} $\boxed{P \ 1 \ 3}$ Function Selection of Pin No. 7 of the External Input / Output Connector A $\textcircled{3}$ " section.) |
| 8 | ERR | Error | Output | ' OFF (Open) ' : Error ' ON (Closed) ' : Normal | Output shows that error has occurred. Error code will be displayed on Digital Speed Indicator $\textcircled{11}$. The error Code Logic can be reversed by setting Parameter $\boxed{P \ 1 \ 1}$. The Error Code Logic can be either Normally Open or Normally Closed depending on the $\boxed{P \ 1 \ 1}$ Setting. In addition, the error code can be output as a patterned signal. For details, refer to "20. SETTING OF OPERATING PARAMETERS". |
| 9 | MT_SEL | Motor Selection | Input | 'OFF (Open)': Motor No. 1 'ON (Closed)': Motor No. 2 | Select the motor to use. |
| 10 | GND | Internal GND for Motor Speed Control Voltage | Output | Internal CONTROLLER GND | This GND will be used for " Motor Speed Control Voltage (VR1/VR2) ". |
| 11 | Vcc | Internal Power Source for Motor Speed Control Voltage | Output | Internal Power Source : DC+10V | Internal Power Source for " Motor Speed Control Voltage (VR1/VR2) ". |
| 12 | MOTOR_I | Motor Current Monitor | Output | 2Amp / V, $0V \leq \text{MOTOR_I} \leq 10V$ | Output Motor Current Monitor with Analog Monitor Voltage. 2Amp / 1V. Max. 20Amp. |
| 13 | GND | Internal GND for Analog Monitor | Output | Internal CONTROLLER GND | This GND will be used for analog monitor (MOTOR_I, SPEED_V, and LOAD). |
| 14 | START | Rotate Command | Input | ' OFF (Open) ' : Stop ' ON (Closed) ' : Start | Motor Start and Motor Stop Signal Setting parameter $\boxed{P \ 8}$, can start with forward rotation. (Refer to " 20 - 4 $\textcircled{8}$ $\boxed{P \ 8}$ Selection of External Motor Start Signal Control Mode" section.) |
| 15 | UD_IN | UP / DOWN Signal for Setting Motor Speed | Input | ' OFF (Open) ' : Speed Down ' ON (Closed) ' : Speed Up | Determines speed up or speed down. Need to set parameter $\boxed{P \ 7}$. (Refer to " 20 - 4 $\textcircled{7}$ $\boxed{P \ 7}$ Selection of External Speed Control Mode " section.) |
| 16 | 500min^{-1} (rpm) | Rotates Motor at " Centering " speed | Input | ' ON (Closed) ' : 500min^{-1} (rpm) ' OFF (Open) ' : Normal Operation | Set motor rotation speed is 500min^{-1} (rpm). Use the Centering Mode. |

| Pin No. | Code | Function | Input / Output | Description | |
|---------|---------|---|----------------|---|--|
| 17 | SEL0 | Motor Select 0 | Input | — | Use when selecting motor, after connecting CONTROLLER to the SELECTOR. 4 motors can be selected by SEL0 and SEL1 combination. (Refer to "17 - 2 - 2 (7) Set Motor Selection Table. 11.") |
| | | Speed Point Select 0 | | | When using CONTROLLER only, Speed Point Signal can be selected. Speed Point (U1 - U4) can be selected by SEL0 and SEL1 signal combination. Refer to "17 - 2 - 2 (5) ③ Set by the Speed Point Signal Table. 10" section. Need to set parameter P_{17} . (Refer to "20 - 4 ⑦ P_{17} Selection of External Speed Control Mode " section.) |
| 18 | COM_2 | External Power Source for External Output | Input | DC0V or DC+24V | Power source to be used for External outputs Signals. |
| 19 | PULSE | Rotating Pulse | Output | 1 pulse / rotation | 1 revolution of the motor generates one pulse. Duty 50%. |
| 20 | WARNING | WARNING | Output | ' OFF (Open) ' : Normal Operation ' ON (Closed) ' : Warning | Output shows that warning has occurred when Parameter P_{19} is set to 00 . Warning code will be displayed on Digital Speed Indicator ①. By setting Parameter P_{17} , the Warning Code can be output as a patterned signal. For details, refer to "20. SETTING OF OPERATING PARAMETERS". |
| | | Load meter level | | ' OFF (Open) ' : Less than set level ' ON (Closed) ' : Set level or more | When Parameter P_{19} is set to 00 , output is performed at a level that exceeds the level set for the load meter. The warning code is displayed on the Digital Speed Indicator ①. Refer to "20 - 4 ⑨ P_{19} Setting Warning Output / Load Meter Illumination Count Output of Pin No. 20 of the External Input / Output Connector A ③". |
| 21 | COIN | Speed Achievement | Output | ' OFF (Open) ' : Set speed not achieved ' ON (Closed) ' : Set speed achieved | Shows that the Motor has achieved more than 90% of the set speed. When Parameter P_{21} is on, the arrival level can be set to 50–100%. (Refer to "20 - 4 ⑫ P_{21} Setting Speed Achievement Level".) |
| 22 | VR2 | Motor No.2 Speed Control Voltage | Input | Motor Spindle No.2 Rotation Control Signal | Sets rotating speed of Motor No. 2. Need to set parameter depending on the motor type. (Refer to "20 - 4 ⑩ P_{17} Selection of Motor Speed Control Voltage / DC+10V Signal Method " section.) Refer to Fig. 60 to 63 about relationship between Motor Speed and Motor Speed Control Voltage (VR). * Unit of rotational speed : 200min ⁻¹ (rpm) |
| 23 | VR1 | Motor No.1 Speed Control Voltage | Input | Motor Spindle No.1 Rotation Control Signal | Sets rotating speed of Motor No. 1. Need to set parameter depending on the motor type. (Refer to "20 - 4 ⑩ P_{17} Selection of Motor Speed Control Voltage / DC+10V Signal Method " section.) Refer to Fig. 60 to 63 about relationship between Motor Speed and Motor Speed Control Voltage (VR). * Unit of rotational speed : 200min ⁻¹ (rpm) |
| 24 | LOAD | Torque Load Monitor | Output | Torque Load Monitor (%) = Torque Load Monitor Voltage x 20 | Shows that the torque being applied to the analog motor. 20% / V 100% (rating) / DC+5V Torque Load Monitor : 0 - 200% (0V ≤ LOAD ≤ 10V) |

| Pin No. | Code | Function | Input / Output | Description | |
|---------|---------|---------------------------------------|----------------|-----------------------------------|---|
| 25 | SPEED_V | Rotating Speed Analog Monitor Voltage | Output | 10,000min ⁻¹ (rpm) / V | Output the rotation speed of rotating motor with Analog Monitor Voltage. 10,000min ⁻¹ (rpm) / V 0V ≤ SPEED_V ≤ 10V |

* Pin assignment can be changed on $\text{P } 14$. For details, refer to " 20 - 3 $\text{P } 14$ Selection of Pin Assignment for the External Input / Output Connector A ③ ".

(2) Input / Output Diagram

The figure below shows the case when Parameter $\text{P } 14$ is set to $\text{30 } \text{①}$ (E3000i). For other settings, refer to Table. 34.

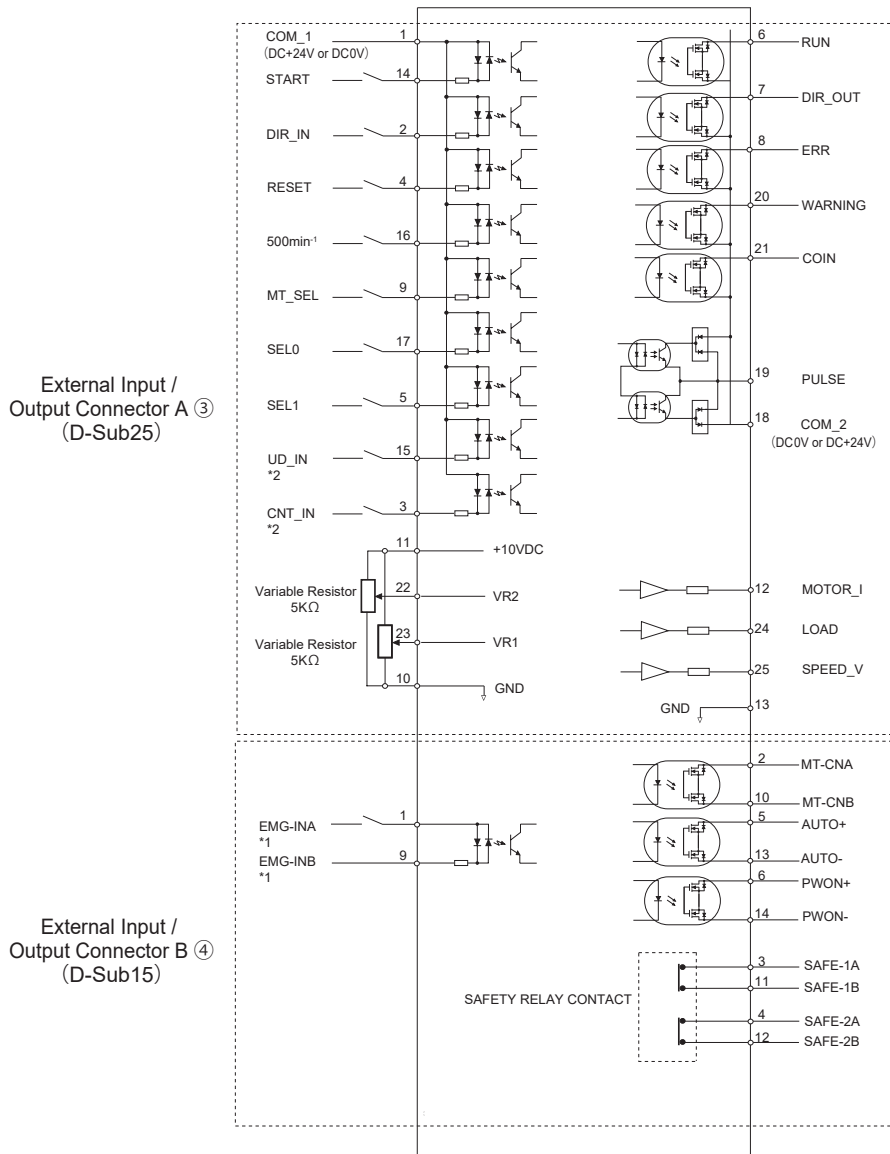

Fig. 42

*1 When using the " EMG - IN " Signal, set parameter $\text{P } 11$. (Refer to " 20 - 4 $\text{P } 11$ Selection of Emergency Stop Function " section.)

*2 When using the " UD_IN and CNT_IN " Signal, set parameter $\text{P } 7$. (Refer to " 20 - 4 $\text{P } 7$ Selection of External Speed Control Mode " section.)

(3) Input / Output Signal

① Input Signal

There are 9 different input signals : " Motor Selection (MT_SEL) ", " Rotate Command (START) ", " Rotating Direction Setting (DIR_IN) ", " Rotates Motor at " Centering " speed (500min^{-1} (rpm)) ", " Error Release (RESET) ", " UP / DOWN Signal for Setting Motor Speed (UD_IN) ", " Count Pulse Signal for Setting Motor Speed (CNT_IN) ", " Motor Select 0 (SEL0) ", and " Motor Select 1 (SEL1) ". These signals are DC+24V signals from an external signal source. Please use a separate power source that is capable of supplying $\text{DC}+24\text{V} \pm 10\%$, 100mA. Refer to Fig. 43 for connections.

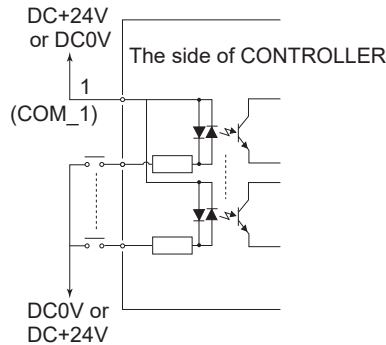

Fig. 43

② Output Signal I

There are 5 separate output signals : " Rotating (RUN) ", " Rotating Direction (DIR_OUT) ", " Error (ERR) ", " WARNING (WARNING) " and " Speed Achievement (COIN) ". These signals are MOSS Relay Contact Connections. The output current can be connected to either sinking or sourcing.

Voltage and Current Specifications

- Applied Voltage (V) $\leq \text{DC}+30\text{V}$
- Working Current (Ip) $\leq 100\text{mA}$

Use an external power source for output circuits. It is recommended to use the same DC+24V power source used for input signals. Please refer to Fig. 44 for connections.

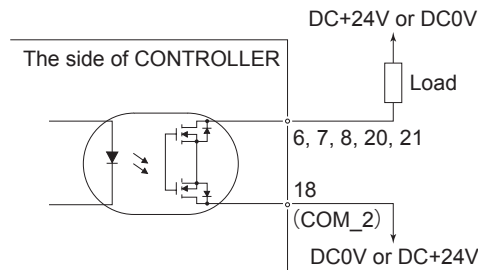

Fig. 44

③ Output Signal II

Refer to Fig. 45 regarding the Output Signal of the " Rotating Pulse (PULSE) ". The output signal can be connected for either sinking or sourcing.

Voltage and Current Specifications

- Applied Voltage (V) $\leq \text{DC}+30\text{V}$
- Working Current (Ip) $\leq 50\text{mA}$

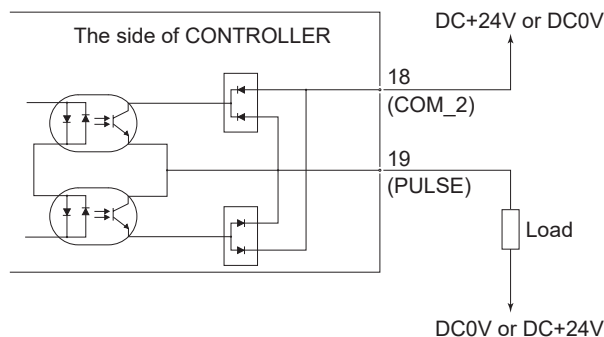

Fig. 45

④ Motor Speed Control Signal

Rotation Speed can be selected by, applying analog voltage to the " Motor Speed Control Voltage (VR1/VR2) " Refer to Fig. 46, 47 for connections. Refer to Fig. 48 to 51 for the relationship between Motor Speed and " Motor Speed Control Voltage (VR1/VR2) ".

CAUTION

When applying the VR1/VR2, never input more than DC+10V to the CONTROLLER (Fig. 47). This will cause serious damage to the I/O Board in the CONTROLLER.

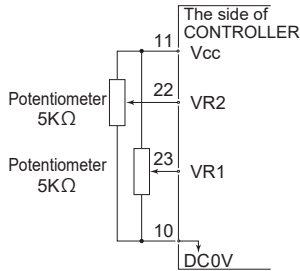

Fig. 46

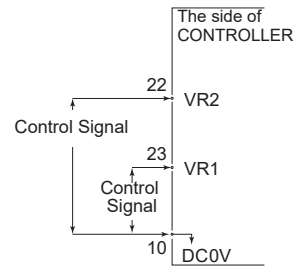

Fig. 47

(1) Other than E2280 Compatible and When Motor other than E2280 is selected

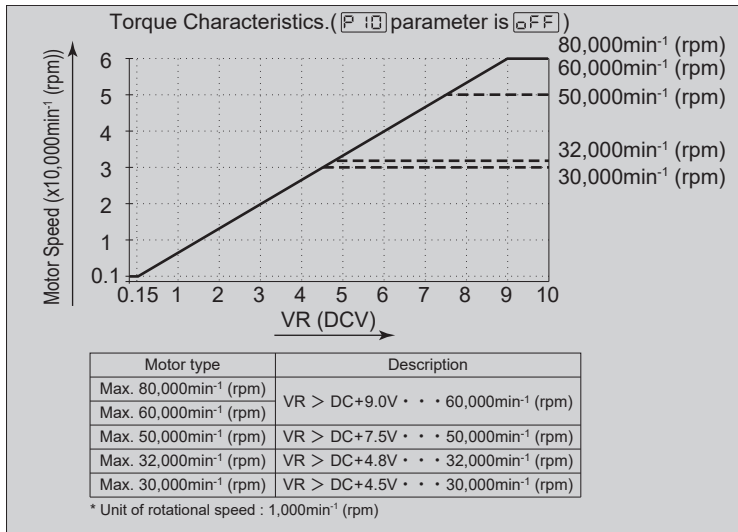

Fig. 48

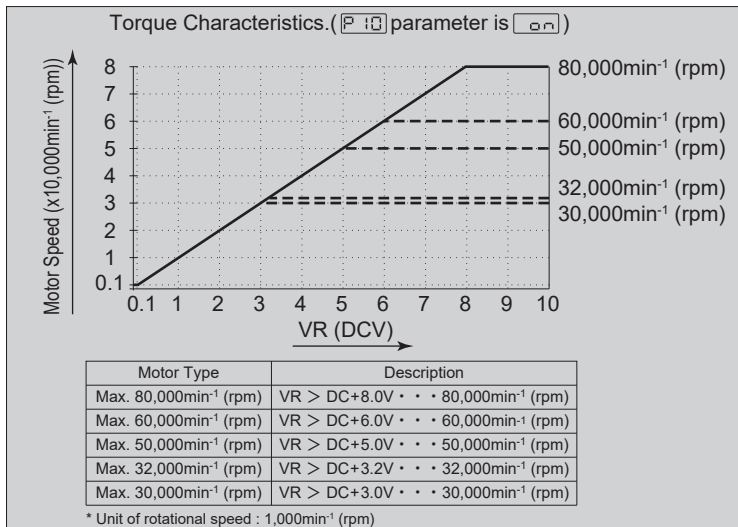

Fig. 49

(2) E2280 Compatible Output or When E2280 Motor is selected

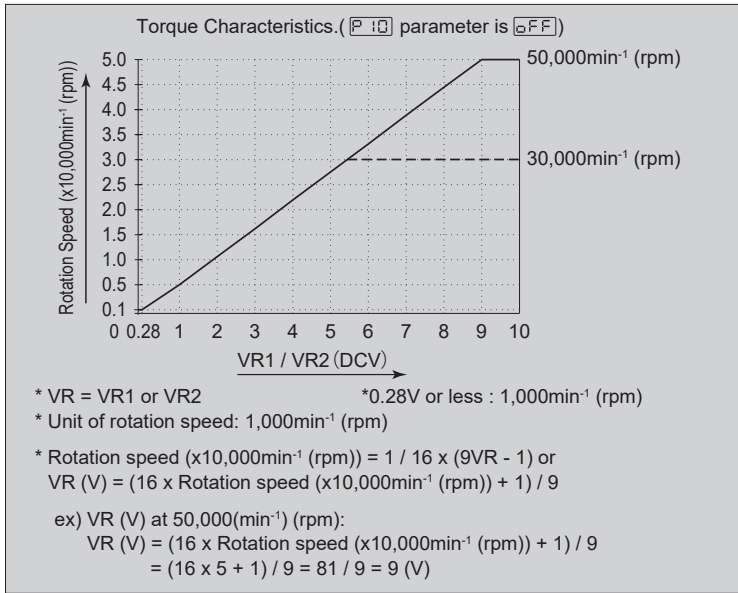

Fig. 50

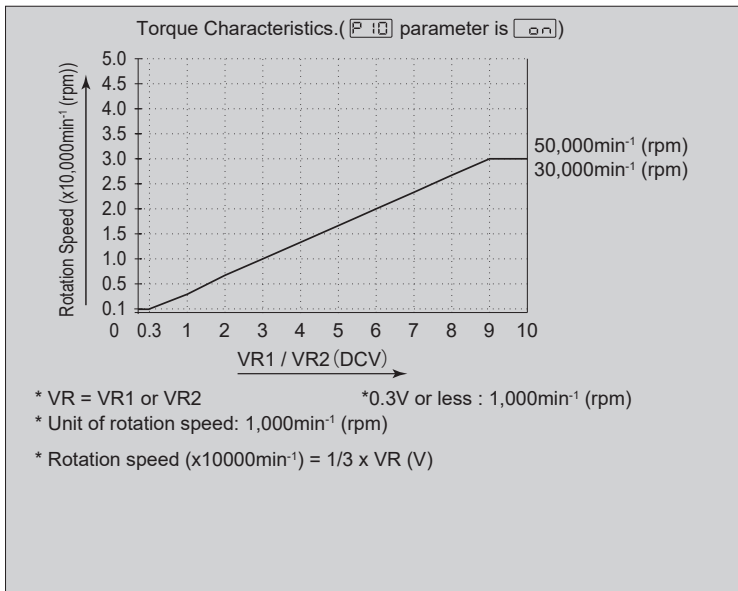

Fig. 51

⑤ Analog Monitor Signals

There are 3 types of monitoring signals : " Motor Current Monitor (MOTOR_I) ", " Torque Load Monitor (LOAD) ", and " Rotating Speed Analog Monitor Voltage (SPEED_V) ". Please refer to Fig. 52 for connections.

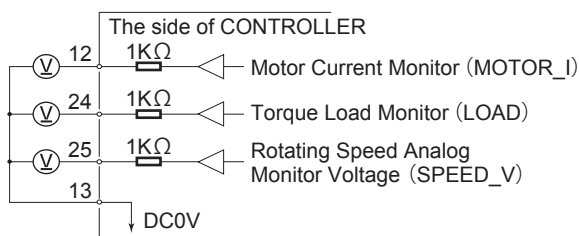

Fig. 52

18 - 2 External Input / Output Connector B ④

(1) Details of External Input / Output Connector B ④ Signals

⚠ WARNING

- DO NOT connect any circuit other than SELV (Safety Extra Low Voltage) to the External Input / Output Connector B ④ of the CONTROLLER. This will cause I / O board damage in the CONTROLLER.
- Do not supply over voltage or over current into the input / output circuit. Always install a LOAD (resistor) to the output circuit to eliminate the chance of damage to the CONTROLLER.

⚠ CAUTION

Input / Output Connector B ④ DOES NOT use Pin No. 7, No. 8, and No. 15. If pin No. 7, No. 8, and No. 15 are connected, the CONTROLLER will be damage.

Table. 13

| Pin No. | Code | Function | Input / Output | Description |
|---------|---------|-------------------------|----------------|--|
| 1 | EMG-INA | Emergency Stop A | Input | External Power Source input for Emergency Stop Signal or Emergency Stop Signal. Normal Operation ' ON (Closed) ', Emergency ' OFF (Open) '. When using the Emergency Stop Signal, set parameter $\boxed{P \ 1 \ 1}$. (Refer to " 20 - 4 ⑩ $\boxed{P \ 1 \ 1}$ Selection of Emergency Stop Function " section.) |
| 2 | MT-CNA | Motor Connect Contact A | Output | Continuity, ' OFF (Open) ', between Pin No. 2 and Pin No. 10 the motor is connected. This signal indicates whether the motor (motor signal line) is connected. When there is continuity, the contacts of Pin No. 2 and Pin No. 10 are OFF (Open). |
| 3 | SAFE-1A | Safety Relay Contact 1A | Output | Pin No. 3 and Pin No. 11 continuity ' ON (Closed) ' Safety Relay is OFF When the Motor No.1 power line is disconnected from the motor power section, Pin No.3 and Pin No.11 are ON (Closed). When the power line is connected, Pin No.3 and Pin No.11 are OFF (Open). |

| Pin No. | Code | Function | Input / Output | Description | |
|---------|----------|-------------------------------------|----------------|---|--|
| 4 | SAFE-2A | Safety Relay Contact 2A | Output | Pin No. 4 and Pin No. 12 continuity ' ON (Closed) ' Safety Relay is OFF | When the Motor No.2 power line is disconnected from the motor power section, Pin No.4 and Pin No.12 are ON (Closed). When the power line is connected, Pin No.4 and Pin No.12 are OFF (Open). |
| 5 | AUTO + | Control Mode AUTO Signal (+) | Output | Control Mode AUTO Pin No. 5 and Pin No. 13 are ' ON (Closed) ' | When Control Mode AUTO is being used, this Pin No. 5 and Pin No. 13 are ' ON (Closed) '. |
| 6 | PWON + | CONTROLLER Power Source Monitor (+) | Output | ' ON (Closed) ' : Main Power Supply is connected ' OFF (Open) ' : Main Power Supply is disconnected | If the Main Power Switch ⑨ is ON, Pin No. 6 and Pin No. 14 are ' ON (Closed) '. |
| 7 | Not Used | — | — | — | *Note : Never use pin labeled not used. |
| 8 | Not Used | — | — | — | *Note : Never use pin labeled not used. |
| 9 | EMG-INB | Emergency Stop B | Input | External Power Source input for Emergency Stop Signal or Emergency Stop Signal ' OFF (Open) ' | External Power Source input for Emergency Stop Signal or Emergency Stop Signal. Normal Operation ' ON (Closed) ', Emergency ' OFF (Open) '. When using the Emergency Stop Signal, set parameter $\boxed{P \quad ; \quad ;}$. (Refer to " 20 - 4 ⑩ $\boxed{P \quad ; \quad ;}$ Selection of Emergency Stop Function" section.) |
| 10 | MT-CNB | Motor Connect Contact B | Output | Continuity, ' OFF (Open) ', between Pin No. 2 and Pin No. 10 the motor is connected. | This signal indicates whether the motor (motor signal line) is connected. When there is continuity, the contacts of Pin No. 2 and Pin No. 10 are OFF (Open). |
| 11 | SAFE-1B | Safety Relay Contact 1B | Output | Pin No. 3 and Pin No. 11 continuity ' ON (Closed) ' Safety Relay is OFF | When the Motor No.1 power line is disconnected from the motor power section, Pin No.3 and Pin No.11 are ON (Closed). When the power line is connected, Pin No.3 and Pin No.11 are OFF (Open). |
| 12 | SAFE-2B | Safety Relay Contact 2B | Output | Pin No. 4 and Pin No. 12 continuity ' ON (Closed) ' Safety Relay is OFF | When the Motor No.2 power line is disconnected from the motor power section, Pin No.4 and Pin No.12 are ON (Closed). When the power line is connected, Pin No.4 and Pin No.12 are OFF (Open). |
| 13 | AUTO - | Control Mode AUTO Signal (-) | Output | Control Mode AUTO Pin No. 5 and Pin No. 13 are ' ON (Closed) ' | When Control Mode AUTO is being used, this Pin No. 5 and Pin No. 13 are ' ON (Closed) '. |
| 14 | PWON - | CONTROLLER Power Source Monitor (-) | Output | ' ON (Closed) ' : Main Power Supply is connected ' OFF (Open) ' : Main Power Supply is disconnected | If the Main Power Switch ⑨ is ON, Pin No. 6 and Pin No. 14 are ' ON (Closed) '. |
| 15 | Not Used | — | — | — | *Note : Never use pin labeled not used. |

(2) Input / Output Signals

① Output Signal

Pin No. 2 - 10, 5 - 13, 6 - 14

There are 3 different output signals : " Motor Connect Contact (MT-CN) ", " Control Mode AUTO Signal (AUTO) ", and " CONTROLLER Power Source Monitor (PWON) ".

These signals are MOSS Relay Contact Connections. The output current can be connected for either sinking or sourcing.

Voltage and Current Specifications

- Applied Voltage (V) \leq DC+30V
- Working Current (Ip) \leq 100mA

Use an external power source for output circuits. It is recommended to use a separate power supply Input / Output Connector B ④ . Please refer to Fig. 53 for connections.

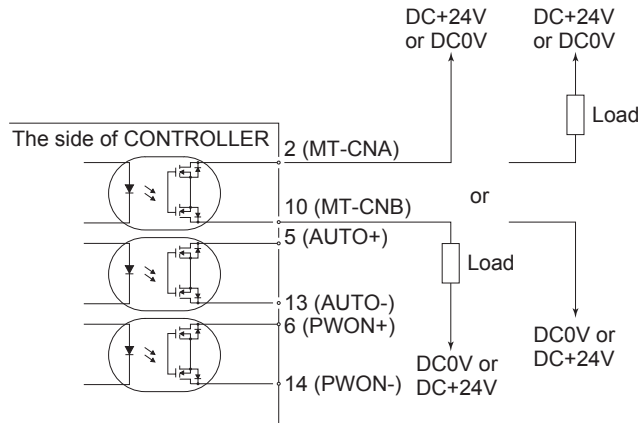

Fig. 53

② Emergency Stop Signal Input

Pin No. 1 - 9

This signal is a switched DC+24V output.

Please use a separate power source that is capable of applying DC+24V \pm 10%, 50mA. Refer to Fig. 54 below for connections.

Normal Operation circuit is ' ON (Closed) ' Emergency Stop circuit is ' OFF (Open) '.

If the Emergency Stop Signal is ' OFF (Open) ' the Safety Relay is OFF and the power supply to the motor is interrupted and the motor stops.

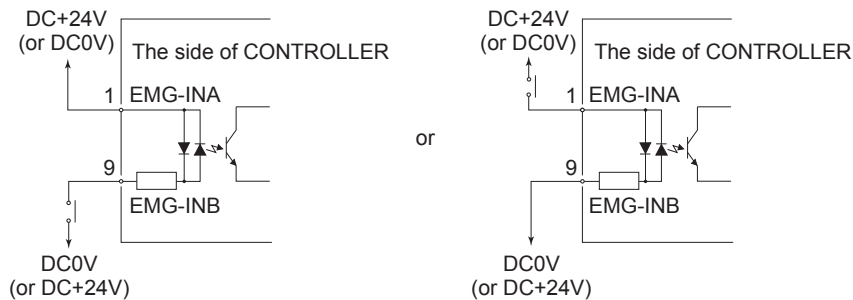

Fig. 54

③ Safety Relay Signal

⚠ CAUTION

If the Emergency Stop Function is disabled, the Emergency Stop Signal (EMG - IN) will not function. If enabling the Emergency Stop Function, it is necessary to set parameter $\boxed{P \quad | \quad | \quad |}$. (Refer to " 20 - 4 ⑪ $\boxed{P \quad | \quad | \quad |}$ Selection of Emergency Stop Function " section.)

⚠ CAUTION (Especially when replacing an E3000 / iSpeed5 system)

The contact outputs (SAFE-1A/SAFE-1B) open/close only when Motor No.1 is selected.
The contact outputs (SAFE-2A/SAFE-2B) open/close only when Motor No.2 is selected.
The contact output on the non-selected motor side remains ON (closed).

Pin No. 3 - 1 1, 4 - 1 2

- The Safety Relay will be ON or OFF depending on the state of the " Emergency Stop (Pin No. 1 : EMG - INA - Pin No. 9 : EMG - INB) ".

'ON' (continuity between EMG-INA and EMG-INB) :

Motor is operating normally. SAFE-1A/-1B and SAFE-2A/-2B are not connected.

'OFF' (no continuity between EMG-INA and EMG-INB) :

Motor power lines are opened circuit, and then Motor is forced to stop. SAFE-1A/-1B and SAFE-2A/-2B are connected.

- Safety Relay with forcibly guided contacts

* Forcibly Guided Contacts (from EN 50205)

If an NO contact becomes welded, all NC contacts will maintain a minimum distance of 0.5 mm when the coil is not energized.

Likewise if an NC contact becomes welded, all NO contacts will maintain a minimum distance of 0.5 mm when then coil is energized.

- The voltage / current specifications of Pin No. 3 - 11 and Pin No. 4 - 12.

Applied Voltage (V) \leq DC+30V

Working Current (Ip) \leq 2A

Refer to Fig. 55 below for connections.

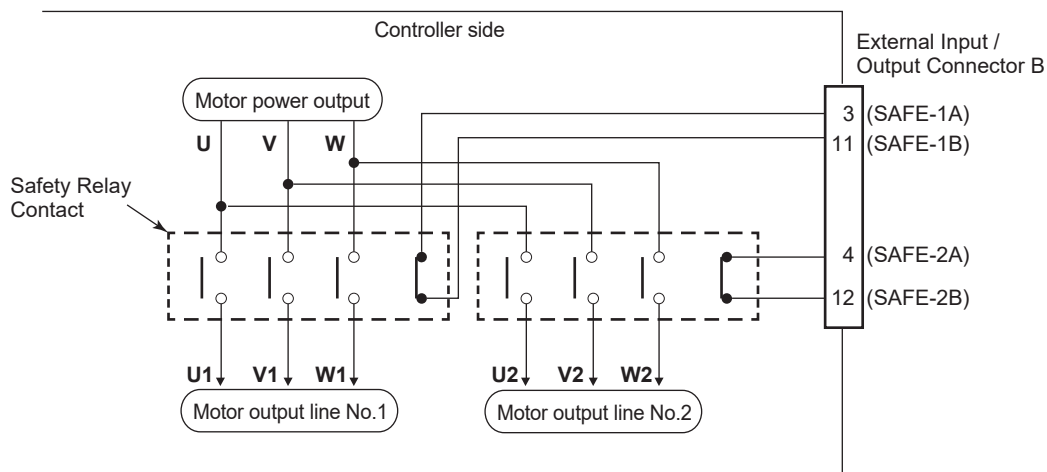

Fig. 55

* Machine Safety Circuit is possible when using the Safety Relay Contacts Output

- When an Emergency Stop Signal input that is coupled to a door open switch of an Industrial Machine, the Safety Relay will energize and open the Motor Power Line circuit.

- Contact outputs ((SAFE - 1A) - (SAFE - 1B), (SAFE - 2A) - (SAFE - 2B)) of the N - C contacts can be used for detecting the opening of the Motor Power Line. If N - O contacts become welded, contact outputs will maintain an OFF condition (Open), by Forced Guide Mechanism. Therefore, Safety Relay can be used as an open signal of a movable guard or operator door with a locking (switch) mechanism for Industrial Machinery.

*Regarding replacement from E3000 / iSpeed5
 The E3000 CONTROLLER had two safety contacts for each motor output (SAFE-1A/SAFE-1B, SAFE-2A/SAFE-2B). (Refer to Fig. 56) However, the E3000i CONTROLLER has one safety contact for Motor Output 1 (SAFE-1A/SAFE-1B) and one for Motor Output 2 (SAFE-2A/SAFE-2B). Please note this difference.

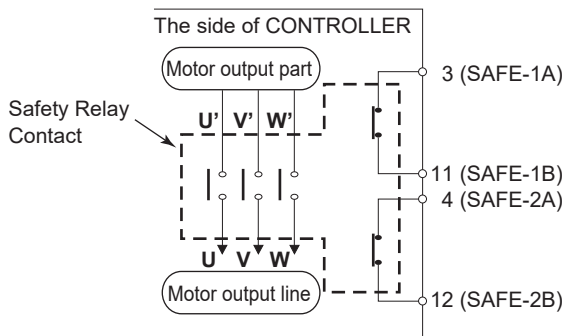

Fig. 56 E3000 / iSpeed5 Safety Relay

18 - 3 External Input / Output Connector Specifications

⚠ CAUTION

- To minimize RF interference and noise, please keep the length of the cables as short as possible and route them separately or as far away as possible from high voltage electrical cables.
- Use only shielded cables to minimize RF interference and noise. Connect the shield to the plug cover.
- Connect the shielded line to the Input / Output connector (The shielded line is grounded). Do not connect another shielded line to any externally powered instrument.

① External Input / Output Connector A ③

Plug Part Number : XM3A - 2521 OMRON (or other similar high - quality product)

Cover Part Number : XM2S - 2511 OMRON (or other similar high - quality product)

② External Input / Output Connector B ④

Plug Part Number : XM3A - 1521 OMRON (or other similar high - quality product)

Cover Part Number : XM2S - 1511 OMRON (or other similar high - quality product)

Please prepare a Cover and Plug.

The shielding should be connected to the Cover.

* Use Mounting Screws that are (M2.6)

Fasten the Connector to the CONTROLLER using Mounting Screws (M2.6).

18 - 4 External Input / Output Connector A ③ / B ④ Pin configuration (Controller side)

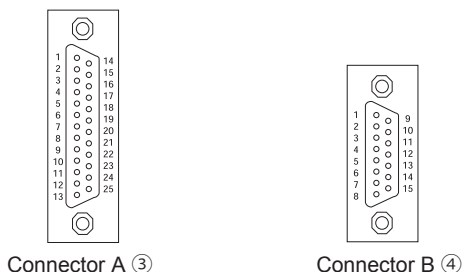

Fig. 57

19. PROTECT FUNCTION

19 - 1 WARNING DETECTION

CAUTION

- When the Warning LED (WARNING) ② blinks, be sure to check the Warning Code and take corrective action.
- At shipment, Parameter $\text{P } 19$ is set to OFF, and the Warning output is disabled.

Always check the CONTROLLER, Motor Spindle and the condition of the cooling air prior to use. This will help prevent system errors that will result in non - operational conditions. When a warning occurs, the following events may occur:

- (1) The WARNING LED (WARNING) ② will blink.
- (2) The Warning Code (listed in Table. 14) will be displayed on the Digital Speed Indicator ① .
- (3) When Parameter $\text{P } 19$ is set to ON, Warning signal (Pin No. 20 : WARNING of the External Input / Output Connector A ③) is ON (Closed).

* By setting Parameter $\text{P } 1$, the output can be changed to Warning Code signal output. (Refer to "20 - 4 (1) $\text{P } 1$ Error output logic settings or error / warning code signal output selection".)

Table. 14

| Warning Code | Warning Function | Trouble |
|--------------|-----------------------|--|
| A0 | Motor Cord | Motor Cord or Connector are not connected or damaged. |
| A1 | Low Air Pressure | Low Air Pressure during motor rotation. |
| A2 | CONTROLLER Overheat | CONTROLLER Overheat. |
| A3 | Over Load | Motor Torque Load exceeding safe limits. |
| A4 | Emergency Stop Signal | Emergency Stop Signal 'OFF (Open)' in Emergency Stop Mode Condition. |
| A5 | Over Air Pressure | Excessive Air Pressure. |

CAUTION

When the Warning LED (WARNING) ② blinks with the control in Mode AUTO, be sure to confirm the Warning Code displayed on the Digital Speed Indicator ① by referring to the " Warning Code " in Table. 12.

19 - 2 Detection of Error (unsafe operating conditions)

Always check the CONTROLLER, motor, spindle and the condition of the cooling air prior to operation. This will help prevent system errors that will result in improper operating conditions.

When an Error Occurs, the following events may occur:

- (1) Motor stops.
- (2) The Error LED (ERROR) ② will light.
- (3) The Error Code in Table. 13 will displayed on Digital Speed Indicator ① .
- (4) An Error signal is output to the " Error (PIN No. 8 : ERR) " of Input / Output Connector A ③ .

* Setting parameter $\text{P } 1$, will Change the Error Output Mode of the Error Signal. (Refer to " 20 - 4 ① $\text{P } 1$ Error output logic settings or error / warning code signal output selection " section.)

19 - 3 Resetting System after Error Codes

There are 2 methods of releasing Error Code.

- (1) When the control is in MANUAL Mode:
Push the Error Reset Button (RESET) ⑱ on the Control Panel ② .

(2) When the control is in AUTO Mode :

Toggle the signal on " Error Release (Pin No. 4 : RESET) " of Input / Output Connector A ③ ' OFF (Open) ' → ' ON (Closed) ' → ' OFF (Open) ' .

* When releasing Error using the " Rotate Command (Pin No. 14 : START) " is ' ON (Closed) ' , ' OFF (Open) ' Motor Start / Stop before resuming operation.

Table. 15

| Error Code | Detection Function | Error Details |
|------------|---|---|
| E1 | Excess Current | Motor Current beyond safe limits. |
| E2 | Over Voltage | Motor Voltage beyond safe limits. |
| E3 | Motor Sensor Malfunction Motor Cord Disconnect | The sensor signal has malfunctioned or Motor Cord Connector is not connected or broken. |
| E4 | CONTROLLER overheat | CONTROLLER overheat. |
| E5 | Break Circuit Trouble | Trouble with the Brake Circuit. |
| E6 | Rotor Lock | Motor Stalled for more than 3 seconds. |
| E7 | Low Air Pressure | Inadequate air is supplied for more than 4 seconds during rotation or inadequate air pressure is supplied when a motor start commanded. |
| E8 | Torque Over Load | Torque limits are exceeded for too long a period of time. (Refer to " 19 - 4 Torque Over Load ".) |
| E9 | Communication Interception | Intercept communication with SELECTOR. (Only if using CONTROLLER connect to SELECTOR.) |
| EA | External Control Signal Error | <ul style="list-style-type: none"> • When Control Mode is in AUTO, the Control Command Signal is ' ON (Closed) ' before Main Power Switch ⑨ is turned ON. • When Control Mode is AUTO, the ERROR command is released without stopping the Control Command Signal ' OFF (Open) ' . |
| EL | Incompatible Motor | An unrecognizable motor is connected to the CONTROLLER. |
| EH | Over Speed | Rotating Speed is beyond the motors capability. |
| EE | Emergency Stop Error | Activated when Emergency Stop Signal is ' OFF (Open) ' , or when rotating, Emergency Stop occurred by Emergency Stop Signal ' OFF (Open) ' . |
| EC | Internal Memory Error | Internal Memory Problem (EEPROM). |
| Ed | Motor Uncontrollable | Motor startup failed or the motor stopped. |
| En | iSpeed3 Compatible Input / Output Not Possible | Pin No. 10 of the External Input / Output Connector A ③ is connected to GND. |

CAUTION

- If when using the Input / Output Connector A ③ / B ④ and External Monitoring, please check and resolve source of the problem whenever an Error Code is displayed on the Digital Speed Indicator ⑩.
- When an error occurs due to internal damage of the CONTROLLER, the Error Signal can not be reset. Please send the Motor spindle and CONTROLLER to a NAKANISHI dealer for repair.

19 - 4 Torque Over Load

CAUTION

If you constantly operate the system in an overload condition, even for short periods of time, the CONTROLLER will overheat and damage to the CONTROLLER, motor and spindle are possible. NAKANISHI recommends only continuous duty operation (LOAD LED's with 3 LED's lit) : Torque Load Monitor (LOAD) ⑫ Voltage should be less than 5V.

When the Load Monitor LED (LOAD) ⑫ lights 4 or more LED' s (3 Blue LED' s and 1 of more yellow LED' s) an over-load condition exists. During a motor overload period, the following will occurs :

- (1) Warning LED (WARNING) ⑫ will blinks.
- (2) Warning Code " A3 " is displayed on the Digital Speed Indicator ⑪ .
- (3) When Parameter $\text{P } 19$ is set to ON, Terminal (No.20 : WARNING) on Details of External Input / Output Connector A ③ turns ON (closed).

Overload operation is considered a short-term operation mode. The allowable operation time depends on the number of lighted LED' s on the Load Monitor LED (LOAD) ⑫.

The allowable time is detailed below.

- (1) Load Monitor LED (LOAD) ⑫ 4 LED's (Blue LED 3, Yellow LED 1) : 30 Seconds
- (2) Load Monitor LED (LOAD) ⑫ 5 LED's (Blue LED 3, Yellow LED 2) : 10 Seconds
- (3) Load Monitor LED (LOAD) ⑫ 6 LED's (Blue LED 3, Yellow LED 2, Red LED 1) : 5 Seconds

When the allowable time is exceeded the motor will stop and the following occurs :

- (1) Error LED (ERROR) ⑪ lights.
- (2) Error Code " E8 " is displayed on the Digital Speed Indicator ⑪ .
- (3) Pin No. 8 (ERR) of the External Input / Output Connector A ③ is ' ON (Closed) '.

* Set the parameter $\text{P } 1$ can be Change the Error Output Mode of the Error Signal for an Open or Closed state. (Refer to " 20 - 4 ① $\text{P } 1$ Error output logic settings or error / warning code signal output selection " section.)

20. SETTING OF OPERATING PARAMETERS

20 - 1 Entering Parameter Setting Mode

CAUTION

When in the parameter mode, normal operation of starting, stopping, etc. operation is not possible.

When changing from the parameter mode to normal operation, be sure to toggle the Main Power Switch ⑨ OFF and ON again.

1. Make sure that the Main Power Switch ⑨ is turned OFF.
2. While push and holding the Error Reset Button (RESET) ⑱ while turning the Main Power Switch ⑨ ON at the front of the CONTROLLER.
3. Hold the Error Reset Button (RESET) ⑱ down for 3 seconds while the CONTROL is powering up. $\text{P } 1$ is Displayed.
4. The buzzer will ' BEEP ' 3 times, then release the Error Reset Button (RESET) ⑱ and Parameter Setting Mode will start. $\text{P } 1$ is Displayed.

20 - 2 Parameter Types

Parameter types, contents, and default are detail in Table. 16.

When checking a parameter or changing a setting, refer to " 20 - 4 Setting procedures " section.

Table. 16

| Code | Types | Contents | Default |
|------|--|---|---------|
| P 1 | Error output logic settings | Changes the Error Output Signal, when an error occurs from normally open to normally closed. | OFF |
| | Error (warning) code signal output selection | The error (warning) code can be output as a patterned signal. | |
| P 2 | Setting AUTO Mode for Motor Speed Control | When the control is in AUTO mode, the speed control is adjustable from the Control Panel ② of the CONTROLLER or the SELECTOR, set the parameter to <input type="checkbox"/> ON to adjust the speed in AUTO Mode. | OFF |
| P 3 | Setting Fixed Motor Speed of Motor No. 1 | When Fixed Motor Speed is desired, set the parameter to <input type="checkbox"/> ON and set the desired locked in speed. (When CONTROLLER and SELECTOR are connected, 4 motors are set to the same motor rotation speed.) | OFF |
| P 4 | Setting Fixed Motor Speed of Motor No. 2 | When Fixed Motor Speed is desired, set the parameter to <input type="checkbox"/> ON and set the desired locked in speed. | OFF |
| P 5 | Setting Maximum Motor Speed of Motor No. 1 | When Maximum Motor Speed is desired, set the parameter to <input type="checkbox"/> ON and set the maximum speed. (When CONTROLLER and SELECTOR are connected, 4 motors are set to the same maximum motor rotation speed.) | OFF |
| P 6 | Setting Maximum Motor Speed of Motor No. 2 | When Maximum Motor Speed is desired, set the parameter <input type="checkbox"/> ON to and set the maximum speed. | OFF |
| P 7 | Selection of External Speed Control Mode | The following Rotation Speed options can be selected when control mode is AUTO. <input type="checkbox"/> AN : Analog Signal <input type="checkbox"/> PLS : Pulse Signal <input type="checkbox"/> SP : Speed Point Signal | AN |
| P 8 | Selection of External Motor Start Signal Control Mode | When control mode is in AUTO, please set the parameter to <input type="checkbox"/> ON and set the desired rotating direction of the motor. Activate Pin 2 to set a reverse direction along with the start command. | OFF |
| P 9 | Selection of Air Input Monitoring Override | If want to start the motor without supplying cooling air, please set the parameter to <input type="checkbox"/> ON. (When set this parameter, motor speed will be limited to 30,000min ⁻¹ (rpm).) | OFF |
| P 10 | Selection of Motor Speed Control Voltage / DC+10V Signal Method | To use the 80,000min ⁻¹ (rpm) motor (or 30,000min ⁻¹ (rpm) motor with E2280 being set) by using Motor Speed Control Voltage when the control mode is set to AUTO, set the parameter to <input type="checkbox"/> ON. | OFF |
| P 11 | Selection of Emergency Stop Function | To use the Emergency Stop Function, set the parameter to <input type="checkbox"/> ON. | OFF |
| P 12 | Selection of RUN Signal Output | You can select the signal of Pin No. 6 of the External Input / Output Connector A ③. <input type="checkbox"/> OFF : Motor rotates. <input type="checkbox"/> ON : Motor stops. | OFF |
| P 13 | Function Selection of Pin No. 7 of the External Input / Output Connector A ③ | You can select the function of Pin No. 7 of the External Input / Output Connector A ③. <input type="checkbox"/> OFF : DIR_OUT <input type="checkbox"/> ON : SEL_MT * If a setting value other than E3000i is selected on Parameter <input type="checkbox"/> P 14, the parameter is set to <input type="checkbox"/> OFF. | OFF |

| Code | Types | Contents | Default |
|------|--|---|--|
| P14 | Selection of Pin Assignment for the External Input / Output Connector A ③ | You can set the pin assignment for the External Input / Output Connector A ③ to compatibility mode with other models. <input type="text" value="301"/> : E3000i <input type="text" value="300"/> : E3000 <input type="text" value="228"/> : E2280 <input type="text" value="153"/> : iSpeed3 <input type="text" value="155"/> : iSpeed5 | <input type="text" value="301"/> |
| P15 | Selection of iSpeed5 Motor | If iSpeed5 is selected on <input type="text" value="P14"/> , the iSpeed5 motor can be selected. <input type="text" value="306"/> : EM-3060ATC <input type="text" value="308"/> : EM-3080ATC <input type="text" value="303"/> : EM-3030T-J <input type="text" value="320"/> : BM-320 <input type="text" value="322"/> : BM-322 | <input type="text" value="306"/> |
| P16 | Selection of E2280 Motor | If E3000i is selected on <input type="text" value="P14"/> , the E2280 motor can be selected. When set to E2280, the E2280 motor is automatically fixed and cannot be changed. <input type="text" value="0FF"/> : Motor other than that of E2280 <input type="text" value="228"/> : EM-2350J | <input type="text" value="0FF"/> |
| P17 | Switching iSpeed5 Motor Air Detection | You can switch enabling and disabling air detection when iSpeed5 motor is used. <input type="text" value="0FF"/> : Air detection is disabled. <input type="text" value="001"/> Air detection is enabled. | <input type="text" value="0FF"/> |
| P18 | Setting Weight of Count Pulse for Speed Setting | You can change the weight of count pulse for external input speed setting. <input type="text" value="0FF"/> : 200min ⁻¹ / pulse <input type="text" value="001"/> : 1,000min ⁻¹ / pulse | <input type="text" value="0FF"/> |
| P19 | Setting Warning Output / Load Meter Illumination Count Output of Pin No. 20 of the External Input / Output Connector A ③ | To enable the warning output, set the parameter to <input type="text" value="001"/> . To synchronize with the load meter illumination count, set the parameter to <input type="text" value="Load"/> , and then set the load meter illumination count. <input type="text" value="0FF"/> : Warning is not output. <input type="text" value="001"/> Warning is output. <input type="text" value="Load"/> : Synchronized with load meter illumination count. | <input type="text" value="0FF"/> |
| P20 | Setting Motor Acceleration / Deceleration Time | To set a desired time from motor startup until the maximum rotation speed is achieved, set the parameter to <input type="text" value="001"/> , and set the desired acceleration / deceleration time from the maximum rotation speed to a stop. | <input type="text" value="0FF"/> |
| P21 | Setting Speed Achievement Level | Set the parameter to <input type="text" value="001"/> to set the desired speed achievement level, if you want to change the actual rotation speed achievement level with respect to the set rotation speed. By default, the rotation speed achievement signal (COIN) is output when 90% of the set rotation speed is achieved. The setting range of the speed achievement level from 50% to 100%. | <input type="text" value="0FF"/> |
| P22 | Error History | Error code history of the last 10 error events can be confirmed. (No parameter setting is necessary.) | <input type="text" value="E--"/> |
| P23 | Motor Usage Cumulative Time | Cumulative time of motor usage can be confirmed. (No parameter setting is necessary.) | <input type="text" value="00-"/> <input type="text" value="00h"/> |
| P24 | Confirmation of Parameter Setting | Contents of the parameters that are set can be confirmed. (<input type="text" value="P1"/> - <input type="text" value="P21"/> .) No parameter setting is necessary.) | |

20 - 3 Contents of Parameters

⚠ CAUTION

Once the parameters are set, the settings will be retained even when the power is turned off. Before use, be sure to thoroughly check the parameter settings and selections.

The following parameters can be set.

- ① **P 1** Error output logic settings or error / warning code signal output selection
- External input and output connector A ③ (terminal No.8: ERR) to select the output of the error signal.
 - To select the output logic of the error signal when an error occurs, select **OFF** or **ON**.
 - Select **cd** to output a patterned error / warning code signal of the error / warning signal when an error / warning occurs.

Table. 17

| Parameter P 1 | Set Contents |
|----------------------|--|
| OFF | Error Occurred : Signal is ' OFF (Open) '. |
| ON | Error Occurred : Signal is ' ON (Closed) '. |
| cd | Error / warning code signal output due to error / warning occurrence |

cd If an error / warning occurs during selection, a signal with the error / warning code patterned as shown below is output.

When an error occurs, an error signal is output to the external Input / Output Connector A ③ (terminal No. 8: ERR). (Refer to Fig. 58.)

When a warning occurs, a warning signal is output to the external Input / Output Connector A ③ (terminal No. 20: WARNING). (Refer to Fig. 59.)

The signal when no error / warning has occurred is OFF (open).

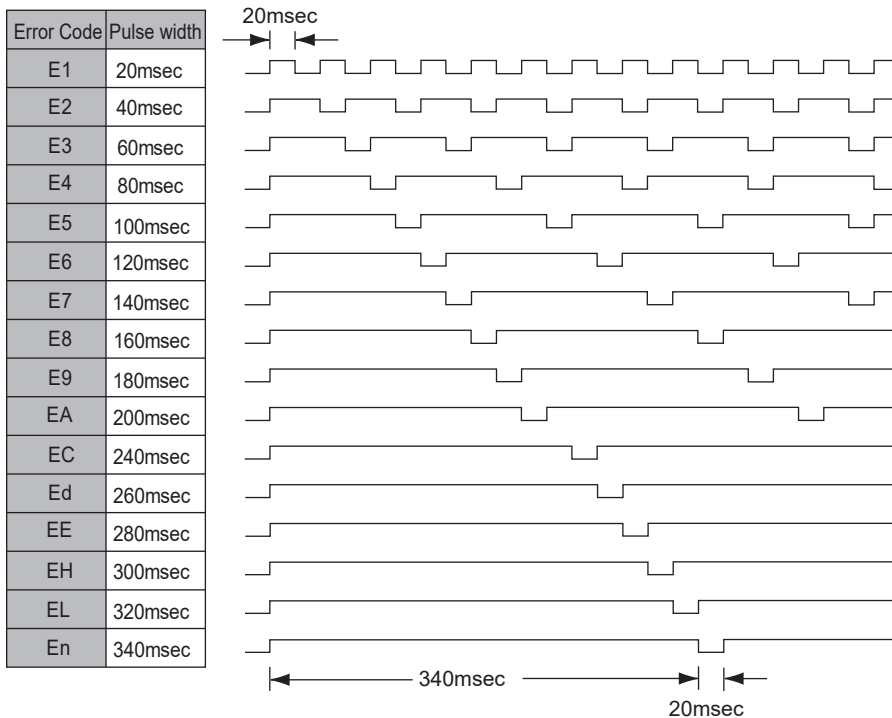

Fig. 58

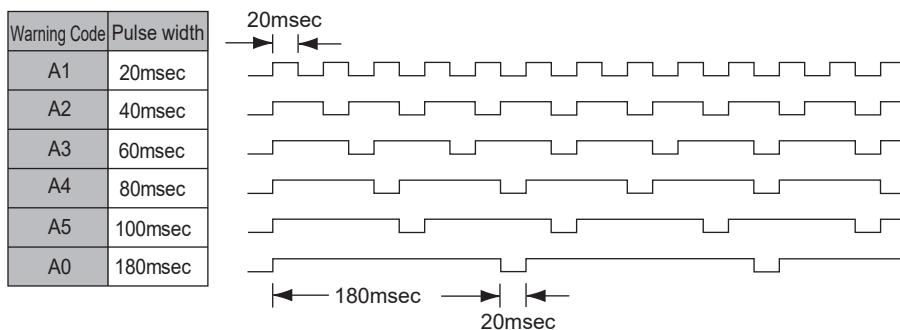

Fig. 59

② **P 2** Setting AUTO Mode for Motor Speed Control

- Allows the setting of the manner in which Motor speed can be controlled when the system is being used in the Controls' AUTO MODE (External Command Signal Control).
- This parameter selects between speed control with the Motor Speed Adjustment Button (▲, ▼) ⑬ of the Control Panel ② or by External Command Signal through Input / Output Connector A ③.

Table. 18

| Parameter P 2 | Set Contents |
|-----------------------------|---|
| <input type="checkbox"/> FF | Set the Motor Rotation Speed by External Command Signal through External Input / Output Connector A ③ . |
| <input type="checkbox"/> 0n | Set the Motor Rotation Speed by Motor Speed Adjustment Button (▲, ▼) ⑬ via the Control Panel ② . |

③ **P 3** Setting Fixed Motor Speed of Motor No. 1

- Allows the Motor speed to be fixed.
- Proactively prevents inadvertent change in speed.
- The Fixed Motor Speed can set by Control Mode MANUAL or AUTO.

Table. 19

| Parameter P 3 | Set Contents |
|-----------------------------|--|
| <input type="checkbox"/> FF | Fixed Motor Speed of Motor No. 1 disabled. |
| <input type="checkbox"/> 0n | Fixed Motor Speed of Motor No. 1 is enabled. |

CAUTION

If you set the rotation speed higher than the rotation speed set at **P 5**, rotation speed will be limited according to **P 5**.

- ④ **P 4** Setting Fixed Motor Speed of Motor No. 2
- Allows the Motor speed to be fixed.
 - Proactively prevents inadvertent change in speed.
 - The Fixed Motor Speed can set by Control Mode MANUAL or AUTO.

Table. 20

| Parameter P 4 | Set Contents |
|----------------------|---|
| OFF | Fixed Motor Speed of Motor No. 2 is disabled. |
| ON | Fixed Motor Speed of Motor No. 2 is enabled. |

⚠ CAUTION

If you set the rotation speed higher than the rotation speed set at **P 6**, rotation speed will be limited according to **P 6**.

- ⑤ **P 5** Setting Maximum Motor Speed of Motor No. 1
- Maximum Motor Speed can be set.
 - Allows a safe machining rotation speed limit.
 - The Maximum Motor Speed can set by Control Mode MANUAL or AUTO.

Table. 21

| Parameter P 5 | Set Contents |
|----------------------|---|
| OFF | Setting of Maximum Motor Speed of Motor No. 1 is not enabled. |
| ON | Setting of Maximum Motor Speed of Motor No. 1 is enabled. |

- ⑥ **P 6** Setting Maximum Motor Speed of Motor No. 2
- Maximum Motor Speed can be set.
 - Allows a safe machining rotation speed limit.
 - The Maximum Motor Speed can set by Control Mode MANUAL or AUTO.

Table. 22

| Parameter P 6 | Set Contents |
|----------------------|---|
| OFF | Setting of Maximum Motor Speed of Motor No. 2 is not enabled. |
| ON | Setting of Maximum Motor Speed of Motor No. 2 is enabled. |

⑦ **P 11** Selection of External Speed Control Mode

- When Control Mode is in AUTO, it is possible to select the External Speed Control Mode from Analog Signal **Rn**, Pulse Signal **Cnt**, or Speed Point Signal Parameter **Pa**. Speed preset in the control according to U1 - U4.

Table. 23

| Parameter P 11 | Set Contents |
|-----------------------|----------------------------------|
| Rn | Set speed by Analog Signal. |
| Cnt | Set speed by Pulse Signal. |
| Pa | Set speed by Speed Point Signal. |

- When setting by Analog Signal **Rn**, use the External Input / Output Signal " Motor Speed Control Voltage (Pin No. 22 : VR2, Pin No. 23 : VR1) ".
- When setting via the Pulse Signal **Cnt**, use the External Input / Output Signal " Count Pulse Signal for Setting Motor Speed (Pin No. 3 : CNT_IN) " and External Input / Output Signal " UP / DOWN Signal for Setting Motor Speed (Pin No.15 : UD_IN) ". The motor speed change per pulse is 200min⁻¹ (rpm) (changeable to 1,000min⁻¹ on Parameter **P 18**).
If " UP / DOWN Signal for Setting Motor Speed " is OFF (Open), the rotation speed decreases, and if it is ON (Closed), the rotation speed increases.
When switching motors, the previously set rotation speed is retained. After switching back, the rotation speed can be set starting from the retained value.
Even if the power is turned OFF, the rotation speeds for Motor No.1 and Motor No.2 are retained.
The maximum allowable pulse-train width is 100 msec.
- When setting by Speed Point Signal **Pa**, and switching motors, first select the desired motor number using the Motor Selection Signal (Pin No. 9: MT_SEL).
Next, select the Speed Point Signal setting using a combination of Speed Point Select 0 (Pin No. 17: SEL0) and Speed Point Select 1 (Pin No. 5: SEL1).
Four different speed points (rotation speeds) can be set for Motor No. 1 and Motor No. 2.
To select speed points (u1.1–u1.4) for Motor No. 1, set the Motor Selection Signal (Pin No. 9: MT_SEL) to OFF (open).
Then, select the desired speed point using the combination of SEL0 (Pin No. 17) and SEL1 (Pin No. 5).

Table. 24 Combination of Motor No.1 Speed Point 0 (Pin No.17: SEL0) and Speed Point 1 (Pin No.5: SEL1)

| Speed Point | SEL1 (Pin No. 5) | SEL0 (Pin No. 17) |
|-------------|------------------|-------------------|
| u1.1 | OFF (Open) | OFF (Open) |
| u1.2 | OFF (Open) | ON (Closed) |
| u1.3 | ON (Closed) | OFF (Open) |
| u1.4 | ON (Closed) | ON (Closed) |

To select Motor No.2 speed points (u2.1–u2.4), set the Motor Selection Signal (Pin No.9: MT_SEL) to ON (closed). Then select the speed point (u2.1–u2.4) using the combination of Speed Point Select 0 (Pin No.17: SEL0) and Speed Point Select 1 (Pin No.5: SEL1).

Table. 25 Combination of Motor No.2 Speed Point 0 (Pin No.17: SEL0) and Speed Point 1 (Pin No.5: SEL1)

| Speed Point | SEL1 (Pin No. 5) | SEL0 (Pin No. 17) |
|-------------|------------------|-------------------|
| u2.1 | OFF (Open) | OFF (Open) |
| u2.2 | OFF (Open) | ON (Closed) |
| u2.3 | ON (Closed) | OFF (Open) |
| u2.4 | ON (Closed) | ON (Closed) |

- The settable rotation speed range for speed points is 1,000–80,000 min⁻¹, adjustable in steps of 200 min⁻¹.

⑧ **P 8** Selection of External Motor Start Signal Control Mode

- When in Auto Control Mode, the Motor Start Signal can be used for either forward or reverse direction by commanding a Direction Signal and a Start Signal. When set, the rotation direction is controlled by " Rotating Direction Setting (Pin No.2 : DIR_IN) ", ' OFF (Open) ' : FWD, ' ON (Closed) ' : REV and the Start Signal is controlled by " Rotate Command (Pin No.14 : START) ".
- When **P 8** is set to **00** FWD rotation is controlled by " Rotate Command (Pin No.14 : START) " and REV rotation is controlled by " Rotating Direction Setting (Pin No.2 : DIR_IN) ".

Table. 26

| Parameter P 8 | Set Contents |
|----------------------|---|
| 0FF | Motor startup and rotating direction is not commanded by signal. |
| 00 | The startup motor with FWD rotation or the startup motor with REV rotation. |

⑨ **P 9** Selection of Air Input Monitoring Override

CAUTION

- **When using without supplying cooling air as recommended, do not spray coolant directly on the spindle body.**
- **Motor start is possible without supplying cooling air, however maximum motor speed is limit to 30,000min⁻¹ (rpm).**

Table. 27

| Parameter P 9 | Set Contents |
|----------------------|----------------------------|
| 0FF | Air detection is enabled. |
| 00 | Air detection is disabled. |

⑩ **P 10** Selection of Motor Speed Control Voltage / DC+10V Signal Method

- Select the Motor Speed Control Voltage Signal and characteristics of the rotational speed according to the motor.

CAUTION

When using the Motor Speed Control Voltage Signal and the maximum motor speed is 80,000min⁻¹ (rpm), it is necessary to set parameter **P 10 to **00** when Control Mode is AUTO.**

Select the Motor Speed Control Voltage and the characteristics of rotational speed.

- (1) Except when E2280 compatible output (parameter **P 14**) and E2280 motor selection (parameter **P 15**) is selected
 - If the parameter is set to **0FF**, the motor characteristics will be set to the motors with maximum rotation speed (60,000min⁻¹ (rpm)).
 - If the parameter is set to **00**, the characteristics will be set to the motors with maximum rotation speed (80,000min⁻¹ (rpm)).
 - For the characteristics of the VR and rotation speed by parameter **00** and **0FF**, refer to Fig. 60 and Fig. 61.
- (2) When of E2280 compatible output (parameter **P 14**) or E2280 motor selection (parameter **P 15**) is selected.

- If parameter is set to $\boxed{\text{FFF}}$, the motor characteristics will be set to the motors with maximum rotation speed ($50,000\text{min}^{-1}$ (rpm)).
- If the parameter is set to $\boxed{\text{000}}$, the characteristic (same speed command characteristic as the former E2530 CONTROLLER) will be applied to motors with a maximum rotation speed of $30,000\text{min}^{-1}$ (rpm).
- For the characteristics of the VR and rotation speed by parameter $\boxed{\text{000}}$ and $\boxed{\text{FFF}}$, refer to Fig. 62 and Fig. 63.

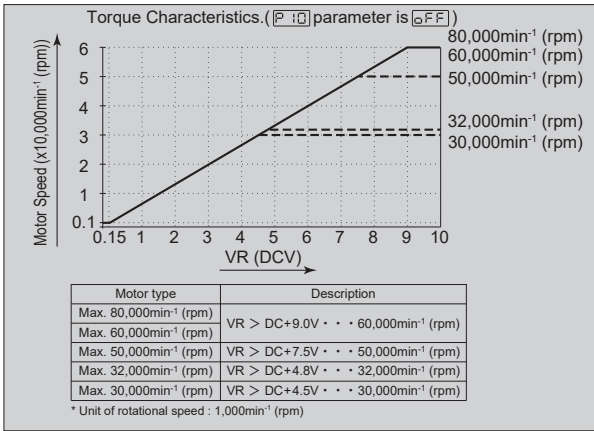

Fig. 60

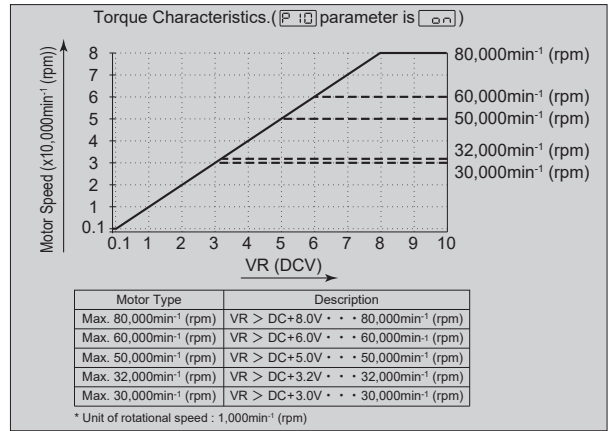

Fig. 61

Table. 28 When neither E2280 compatible output (Parameter $\boxed{\text{P14}}$) nor E2280 motor selection (Parameter $\boxed{\text{P1E}}$) is selected

| Parameter $\boxed{\text{P1Q}}$ | Set Contents |
|--------------------------------|---|
| $\boxed{\text{FFF}}$ | The characteristics of the motors maximum rotation speed $60,000\text{min}^{-1}$ (rpm). |
| $\boxed{\text{000}}$ | The characteristics of the motors maximum rotation speed $80,000\text{min}^{-1}$ (rpm). |

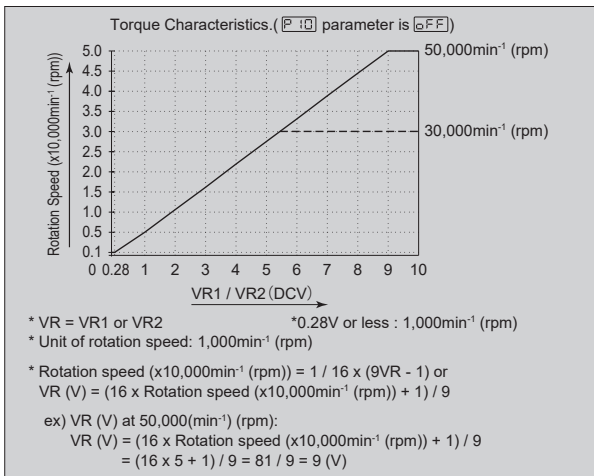

Fig. 62

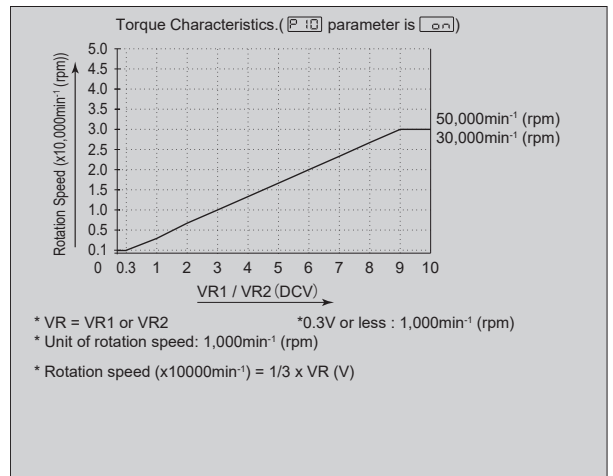

Fig. 63

Table. 29 E2280 Compatible Output (Parameter $\boxed{\text{P14}}$) or When E2280 Motor (Parameter $\boxed{\text{P1E}}$) is selected

| Parameter $\boxed{\text{P1Q}}$ | Set Contents |
|--------------------------------|--|
| $\boxed{\text{FFF}}$ | The characteristics of Motor Speed Control for $50,000\text{min}^{-1}$ motor |
| $\boxed{\text{000}}$ | The characteristics of Motor Speed Control for $30,000\text{min}^{-1}$ motor (Same speed command characteristic as the former E2530 CONTROLLER) |

⑪ **P 11** Selection of Emergency Stop Function

- The Emergency Stop Function can be enabled or disabled.
- When " Emergency Stop A (Pin No.1 : EMG - INA) " and " Emergency Stop B (Pin No.9 : EMG - INB) " of the External Input / Output Connector B ④'s input signal are set to ' OFF (Open) ', Safety Relay will activate and block the Motor Power Line and make an emergency stop.
Normally, " Emergency Stop A (Pin No.1 : EMG - INA) " and " Emergency Stop B (Pin No.9 : EMG - INB) " input signal need to be set to ' ON (Closed) '.
- Allows the establishment of a safe machine operating system.

Table. 30

| Parameter P 11 | Set Contents |
|-----------------------------|---|
| <input type="checkbox"/> FF | Emergency Stop Function is deactivated. |
| <input type="checkbox"/> ON | Emergency Stop Function is activated. |

⑫ **P 12** Selection of RUN Signal Output

- You can select the signal of Pin No. 6 of the External Input / Output Connector A ③ .
- If the parameter is set to FF, the output signal is set to ON (Closed) when the motor is rotating.
- If the parameter is set to ON, the output signal is set to ON (Closed) when the motor is stopped.

Table. 31

| Parameter P 12 | Set Contents |
|-----------------------------|-----------------------|
| <input type="checkbox"/> FF | Motor rotation signal |
| <input type="checkbox"/> ON | Motor stop signal |

⑬ **P 13** Function Selection of Pin No. 7 of the External Input / Output Connector A ③

- You can select the signal of Pin No. 7 of the External Input / Output Connector A ③ .
- If the parameter is set to FF, the function of Pin No. 7 of the External Input / Output Connector A ③ .is set to DIR_OUT.
- If the parameter is set to ON, the function of Pin No. 7 of the External Input / Output Connector A ③ .is set to SEL_MT (motor selection).
In this case, when motor No. 1 is selected, the output signal is OFF (Open), and when motor No. 2 is selected, the output signal is set to ON (Closed).
- If a setting value other than E3000i is selected on Parameter **P 14**, this setting is set to FF.

Table. 32

| Parameter P 13 | Set Contents |
|-----------------------------|--------------|
| <input type="checkbox"/> FF | DIR_OUT |
| <input type="checkbox"/> ON | SEL_MT |

⑭ P 14 Selection of Pin Assignment for the External Input / Output Connector A ③

- You can set the pin assignment for the External Input / Output Connector A ③ to compatibility mode with other models.
- If the parameter is set to , the pin assignment for the External Input / Output Connector A ③ is set to E3000i mode.
- If the parameter is set to , the pin assignment for the External Input / Output Connector A ③ is set to E3000 compatible mode.
- If the parameter is set to , the pin assignment for the External Input / Output Connector A ③ is set to E2280 compatible mode.
- If the parameter is set to , the pin assignment for the External Input / Output Connector A ③ is set to iSpeed3 compatible mode.
- If the parameter is set to , the pin assignment for the External Input / Output Connector A ③ is set to iSpeed5 compatible mode.

In this case, air detection is disabled, and motor No. 2 cannot be selected.

For the pin assignment for the External Input / Output Connector A ③ by parameter , , , , and , refer to Table. 34

Table. 33

| Parameter <input type="text" value="P 14"/> | Set Contents |
|---|--------------------------|
| <input type="text" value="30"/> | E3000i mode |
| <input type="text" value="300"/> | E3000 compatible mode |
| <input type="text" value="228"/> | E2280 compatible mode |
| <input type="text" value="1_3"/> | iSpeed3 compatible mode |
| <input type="text" value="1_5"/> | iSpeed5 compatible mode* |

* If the motor to be used and the motor type signal No. 0/1 setting do not match, the motor does not rotate properly.

Table. 34

| Pin No. | 30i | 300 | 228 | i_3 | i_5 |
|---------|----------------------|----------------------|----------------------|----------|----------|
| A-1 | COM_1 | COM_1 | COM_1 | COM_1 | COM_1 |
| A-2 | DIR_IN | DIR_IN | DIR_IN | DIR_IN | DIR_IN |
| A-3 | CNT_IN | CNT_IN | VR2 | CNT_IN | CNT_IN |
| A-4 | RESET | RESET | RESET | RESET | RESET |
| A-5 | SEL1 | SEL1 | SEL1/CNT_IN*2 | SEL1 | SEL1 |
| A-6 | RUN | RUN | RUN | RUN | RUN |
| A-7 | DIR_OUT/SEL_MT*1 | DIR_OUT | DIR_OUT | DIR_OUT | DIR_OUT |
| A-8 | ERR | ERR | ERR | ERR | ERR |
| A-9 | MT_SEL | Not used | SEL_MT | MT_SEL | ID0*4 |
| A-10 | GND | GND | GND | SEL_MT | Not used |
| A-11 | Vcc | Vcc | Vcc | Vcc | Vcc |
| A-12 | MOTOR_I | MOTOR_I | MOTOR_I | MOTOR_I | MOTOR_I |
| A-13 | GND | GND | GND | GND | GND |
| A-14 | START | START | START | START | START |
| A-15 | UD_IN | UD_IN | MT_SEL | UD_IN | UD_IN |
| A-16 | 500min ⁻¹ | 500min ⁻¹ | 500min ⁻¹ | Not used | Not used |
| A-17 | SEL0 | SEL0 | SEL0/UD_IN*3 | SEL0 | SEL0 |
| A-18 | COM_2 | COM_2 | COM_2 | COM_2 | COM_2 |
| A-19 | PULSE | PULSE | PULSE | PULSE | PULSE |
| A-20 | WARNING | WARNING | WARNING | WARNING | WARNING |
| A-21 | COIN | COIN | COIN | COIN | COIN |
| A-22 | VR2 | Not used | Not used | VR2 | ID1*5 |
| A-23 | VR1 | VR1 | VR1 | VR1 | VR1 |
| A-24 | LOAD | LOAD | LOAD | LOAD | LOAD |
| A-25 | SPEED_V | SPEED_V | SPEED_V | SPEED_V | SPEED_V |

*1 To use as SEL_MT, set to on the Parameter setting.

(Refer to " 20- 4 Function Selection of Pin No. 7 of the External Input / Output Connector A ".)

| | | | | | |
|-----|------------------|---------|---------|---------|---------|
| A-7 | DIR_OUT/SEL_MT*1 | DIR_OUT | DIR_OUT | DIR_OUT | DIR_OUT |
|-----|------------------|---------|---------|---------|---------|

*2 To use as CNT_IN, set to on the Parameter setting.

(Refer to " 20 - 4 Selection of External Speed Control Mode ".)

*3 To use as UD_IN, set to on the Parameter setting.

(Refer to " 20 - 4 Selection of External Speed Control Mode ".)

*4 Motor Type Signal 0 : Select the type of motor to be used. Select by the 2 signals ID0 and ID1.

*5 Motor Type Signal 1 : Select the type of motor to be used. Select by the 2 signals ID0 and ID1.

Table. 35

| Motor Type | Motor Type Signal 1 (ID1) | Motor Type Signal 0 (ID0) |
|------------|---------------------------|---------------------------|
| EM-3060ATC | OFF (Open) | OFF (Open) |
| EM-3080ATC | OFF (Open) | ON (Closed) |
| EM-3030T-J | ON (Closed) | OFF (Open) |
| BM-320 | ON (Closed) | ON (Closed) |

⑮ **P 15** Selection of iSpeed5 Motor

- When Parameter **P 14** is set to iSpeed5-compatible mode, an iSpeed5 motor can be selected.

CAUTION

- **When a motor for iSpeed5 is selected, air pressure is not detected. Be sure to supply air for cooling the motor spindle and for air purging.**
- **If the motor to be used and the selected motor do not match, the motor does not rotate properly.**

- If the parameter is set to **306**, "EM-3060ATC" is selected.
- If the parameter is set to **308**, "EM-3080ATC" is selected.
- If the parameter is set to **303**, "EM-3030T-J" is selected.
- If the parameter is set to **320**, "BM-320" is selected.
- If the parameter is set to **322**, "BM-322" is selected.
- Air detection is disabled, and motor No. 2 cannot be selected.
- For the motor selection by parameter **306**, **308**, **303**, **320**, and **322**, refer to Table. 36.

Table. 36

| Parameter P 15 | Set Contents |
|-----------------------|----------------------------|
| 306 | EM-3060ATC (iSpeed5 Motor) |
| 308 | EM-3080ATC (iSpeed5 Motor) |
| 303 | EM-3030T-J (iSpeed5 Motor) |
| 320 | BM-320 (iSpeed5 Motor) |
| 322 | BM-322 (iSpeed5 Motor) |

⑯ **P 16** Selection of E2280 Motor

- If E3000i is selected on **P 14**, the E2280 motor can be selected for motor No. 1 and No. 2.
If E2280 is compatible mode selected on **P 14**, the E2280 motor is automatically selected for motor No. 1 and No. 2.
- If the parameter is set to **off**, motors other than that of E2280 are automatically recognized.
- If the parameter is set to **on**, the E2280 motor is selected.
- If the motor to be used and the selected motor do not match, the motor does not rotate properly.

Table. 37

| Parameter P 16 | Set Contents |
|-----------------------|------------------------|
| off | Motor other than E2280 |
| on | E2280 motor (EM-2350J) |

⑰ **P 17** Switching iSpeed5 Motor Air Detection

- You can switch enabling and disabling air detection, when iSpeed5 motor is used.

Table. 38

| Parameter P 17 | Set Contents |
|-----------------------|----------------------------|
| off | Air detection is disabled. |
| on | Air detection is enabled. |

⑱ **P 18** Setting Weight of Count Pulse for Speed Setting

- You can change the weight of count pulse for external input speed setting.
- If the parameter is set to **OFF**, the weight of count pulse for external input speed setting is set to 200min⁻¹/ pulse.
- If the parameter is set to **ON**, the weight of count pulse for external input speed setting is set to 1,000min⁻¹ / pulse.

Table. 39

| Parameter P 18 | Set Contents |
|-----------------------|--------------------------------|
| OFF | 200min ⁻¹ / pulse |
| ON | 1,000min ⁻¹ / pulse |

⑲ **P 19** Setting Warning Output / Load Meter Illumination Count Output of Pin No. 20 of the External Input / Output Connector A ③

- To enable the warning output of Pin No. 20 of the External Input / Output Connector A ③, set this parameter to **ON**.
- To synchronize Pin No. 20 of the External Input / Output Connector A ③ with the load meter illumination count, set this parameter to **Load**, and then set the load meter illumination count. The design range of the illumination count is from 2 to 6. (Refer to Table. 41.)

Table. 40

| Parameter P 19 | Set Contents |
|-----------------------|--|
| OFF | No warning is output. |
| ON | Warning is output. |
| Load | Synchronized with load meter illumination count. |

Table. 41

| Setting value | Load meter illumination count. |
|---------------|--|
| 2 | ON (Closed) if two or more illuminate. |
| 3 | ON (Closed) if three or more illuminate. |
| 4 | ON (Closed) if four or more illuminate. |
| 5 | ON (Closed) if five or more illuminate. |
| 6 | ON (Closed) if six or more illuminate. |

⑳ **P20** Setting Motor Acceleration / Deceleration Time

- Set the time from motor startup until the maximum rotation speed is achieved, and the deceleration time from the maximum rotation speed to a stop.
The value is indicated in unit of second. The setting range of the acceleration time is from 4 to 60 seconds. (Refer to Table. 43.)
- The set time is applied in common to acceleration and deceleration time.

Table. 42

| Parameter P20 | Set Contents |
|-----------------------------|---|
| <input type="checkbox"/> FF | Motor acceleration / deceleration time setting is disabled (2 seconds). |
| <input type="checkbox"/> on | Motor acceleration / deceleration time setting is enabled. |

Table. 43

| Setting value (Unit : Seconds) | Display |
|--------------------------------|---------|
| 4 | 4 |
| 6 | 6 |
| 8 | 8 |
| 10 | 10 |
| 12 | 12 |
| 14 | 14 |
| 16 | 16 |
| 18 | 18 |
| 20 | 20 |
| 25 | 25 |
| 30 | 30 |
| 45 | 45 |
| 60 | 60 |

㉑ **P21** Setting Speed Achievement Level

- Set this parameter to on to set the desired speed achievement level, if you want to change the actual rotation speed achievement level with respect to the set rotation speed.
- By default, the rotation speed achievement signal (Pin No. 21 : COIN of the External Input / Output Connector A ③) is output when 90% of the set rotation speed is achieved.
- Settable range is from 50% to 100% in 1% increments.

Table. 44

| Parameter P21 | Set Contents |
|-----------------------------|---|
| <input type="checkbox"/> FF | Speed achievement level setting is disabled (90%). |
| <input type="checkbox"/> on | Speed achievement level setting is enabled. 50 to 100 (%) * In 1% increments * Default value : 90% |

②② **P22** Error History

- The Error History, which records previous error codes can be confirmed by the Error Code displayed on the digital Speed Indicator ⑪.
- Records Error Codes for viewing when machines are being run unattended.
- In case there is no Error History, **E. - -** will be displayed on the Digital Speed Indicator ⑪.
- The last Error Code recorded will be **H. !** and the oldest will be **H. 10**. The Error code is displayed on the Digital Speed Indicator ⑪.
- If Error History contains more than ten errors, oldest Error History **H. 10** will be deleted.
- To erase the Error History, press and hold the START / STOP Button (START / STOP) ⑭ for 3 seconds. The buzzer beeps and all the error history is cleared.

②③ **P23** Motor Usage Cumulative Time

- Cumulative time of motor usage can be confirmed.
- Usage time for individual motor No. is accumulated.
- From 0 to 9,999 hours (416 days) in unit of 1 hour can be accumulated. For 9,999 hours or more of cumulative time, the display will remain 9,999 hours.
- The last two digits of the cumulative time are displayed as **00h**, and the first two digits are displayed as **00-**.
- To erase the cumulative time, press and hold the START / STOP Button (START / STOP) ⑭ for 3 seconds. The buzzer beeps and the cumulative time is cleared.

②④ **P24** Confirmation of Parameter Setting

- This mode allows the user to check the settings of parameters **P 1** - **P21**. The parameter **P22** and **P23** cannot be checked.

20 - 4 Setting Procedures

① **P 1** Error output logic settings or error / warning code signal output selection

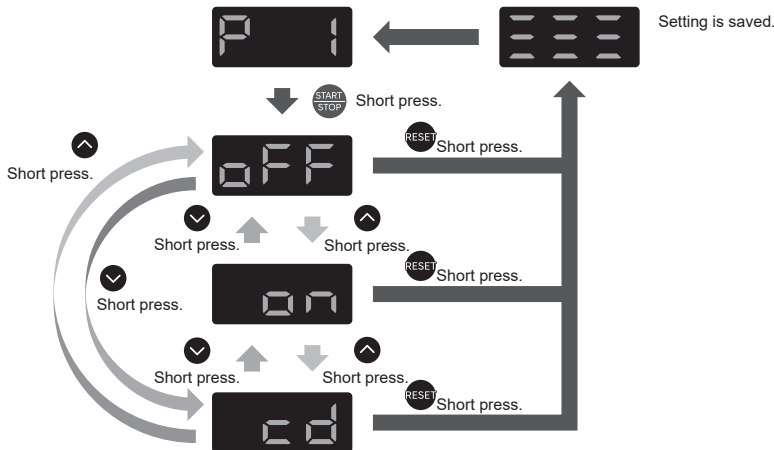

When an error occurs, the output will be 'OFF (Open)'.



When an error occurs, the output will be 'ON (Closed)'.



When an error/warning occurs, the error/warning code is output as a patterned signal.

To exit the parameter mode, turn the Main Power Switch ⑨ OFF.

② Setting AUTO Mode for Motor Speed Control

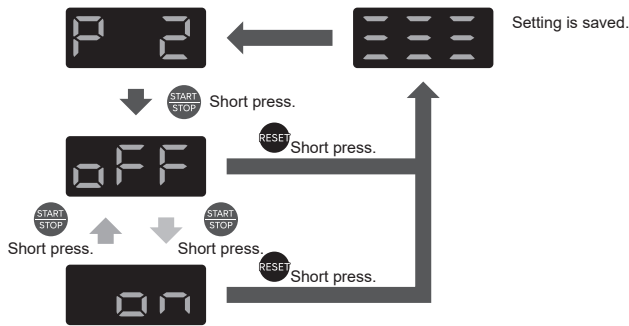

Setting motor rotation speed on the control panel ② is not available.



Setting motor rotation speed on the control panel ② is available.

To exit the parameter mode, turn the Main Power Switch ⑨ OFF.

③ Setting Fixed Motor Speed of Motor No. 1

CAUTION

Actual motor rotation speed of the motor will be limited, based on maximum motor rotation speed and the type of motor connected.

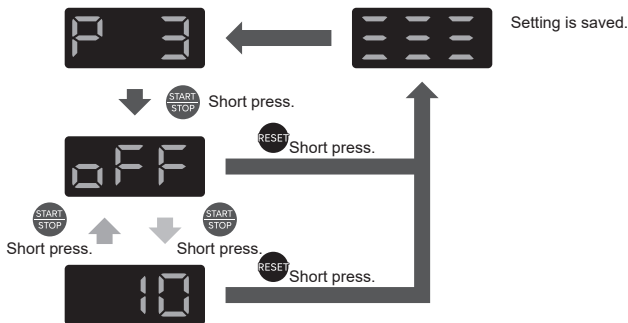

- ⬆ Set the rotation speed of motor No. 1.
- ✓ 10 to 800 (× 100min⁻¹)

To exit the parameter mode, turn the Main Power Switch ⑨ OFF.

④ **P 4** Setting Fixed Motor Speed of Motor No. 2

CAUTION

Actual motor rotation speed of the motor will be limited, based on maximum motor rotation speed and the type of motor connected.

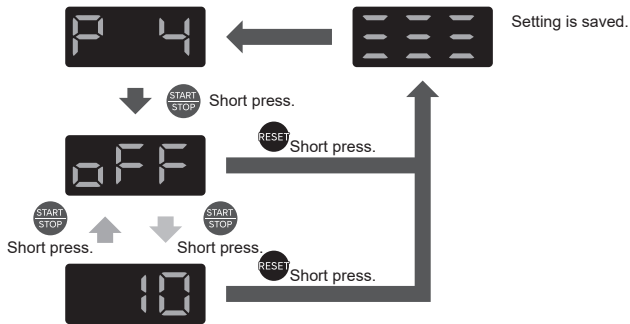

- ⤴ Set the rotation speed of motor No. 2.
- ⤵ 10 to 800 (× 100min⁻¹)

To exit the parameter mode, turn the Main Power Switch ⑨ OFF.

⑤ **P 5** Setting Maximum Motor Speed of Motor No. 1

CAUTION

Actual motor rotation speed of the motor will be limited, based on maximum motor rotation speed and the type of motor connected.

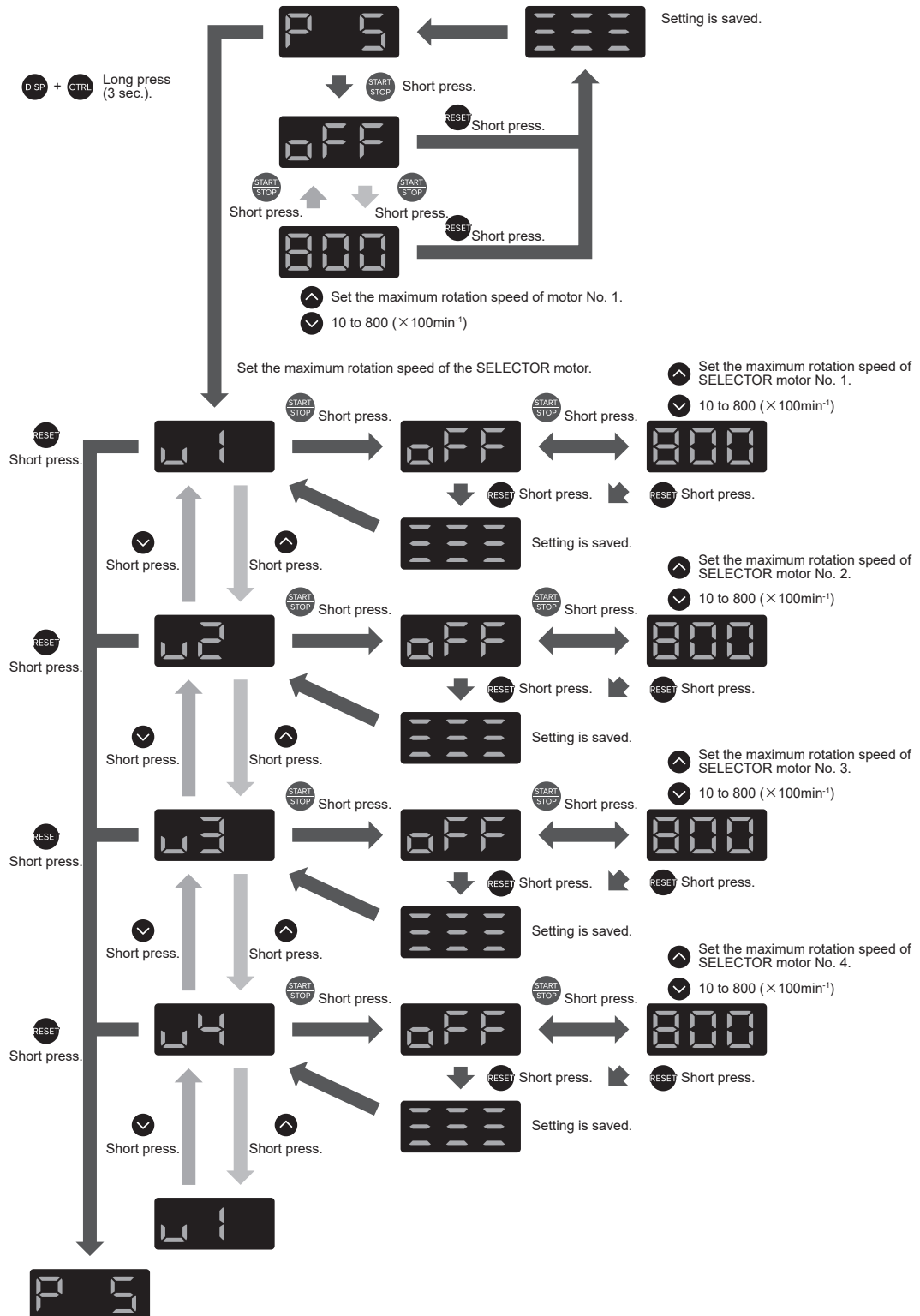

To exit the parameter mode, turn the Main Power Switch ⑨ OFF.

⑥ **P 5** Setting Maximum Motor Speed of Motor No. 2

CAUTION

Actual motor rotation speed of the motor will be limited, based on maximum motor rotation speed and the type of motor connected.

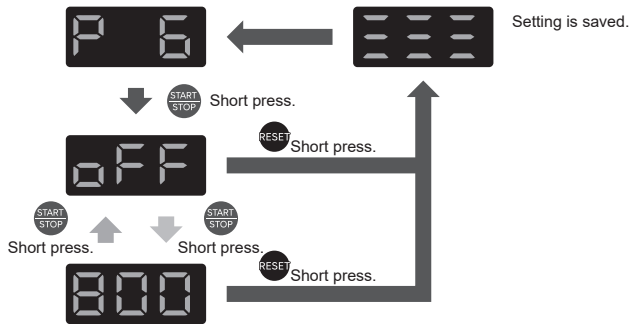

- ⬆ Set the maximum rotation speed of motor No. 2.
- ⬇ 10 to 800 (× 100min⁻¹)

To exit the parameter mode, turn the Main Power Switch ⑨ OFF.

⑦ **P 7** Selection of External Speed Control Mode

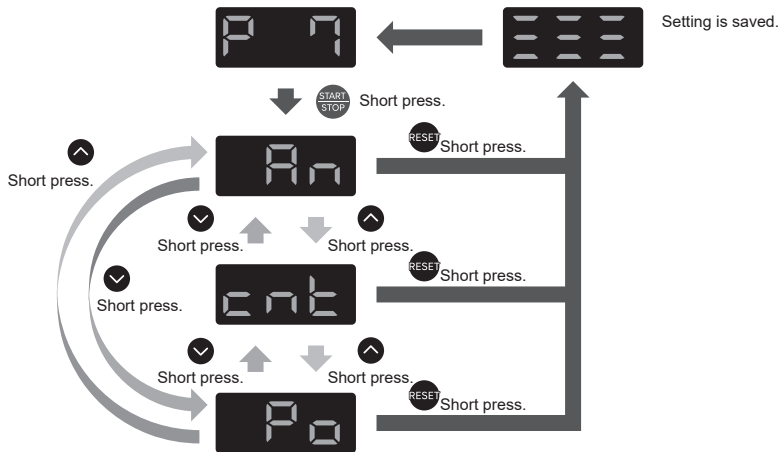

- An** Set the motor rotation speed by Motor Speed Control Voltage.
- ent** Set the motor rotation speed by Pulse Signal.
- Pa** Four different speed points can be set for Motor No.1 and Motor No.2. Refer to the next page for the setting procedure.

To exit the parameter mode, turn the Main Power Switch ⑨ OFF.

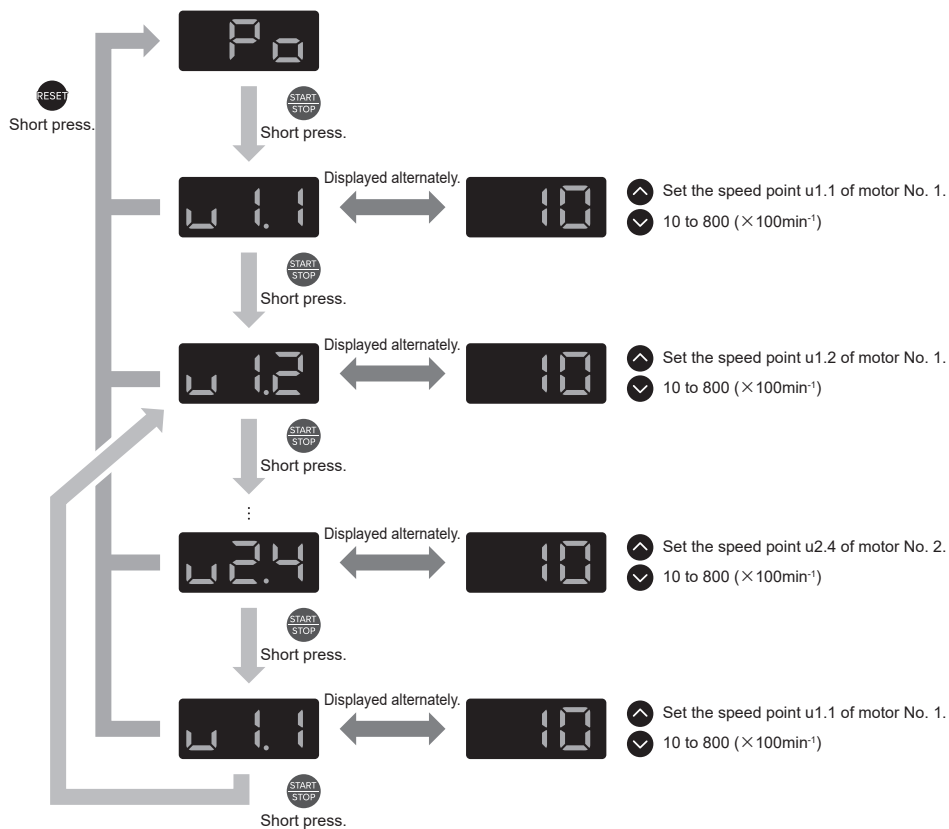

* If you return to Po from u1.2 by pressing and holding **RESET** and when you press **START/STOP** next time, u1.2 (speed point that is currently set) will be displayed.

⑧ P 8 Selection of External Motor Start Signal Control Mode

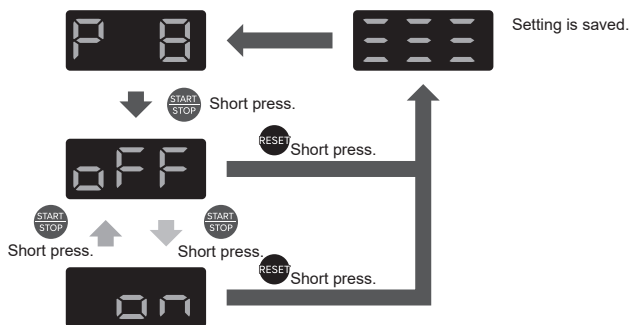

Motor startup and setting the rotation direction cannot be performed simultaneously.



Clockwise rotation (FWD) with motor startup by "Rotation Command (Pin No. 14: START)" or counterclockwise rotation (REV) with motor startup by "Rotating Direction Setting (Pin No. 2: DIR_IN)" can be set.

To exit the parameter mode, turn the Main Power Switch ⑨ OFF.

⑨ P 9 Selection of Air input Monitoring Override

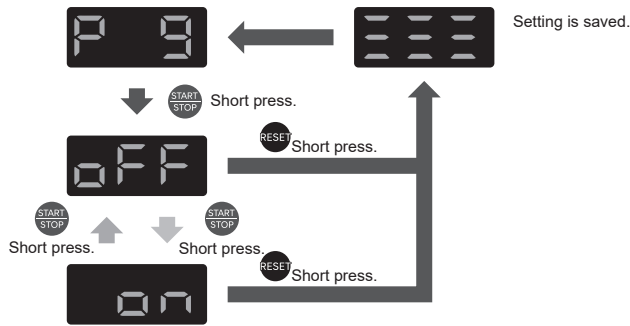

Without air supply, the motor cannot be started.



The motor can be started without air supply.
However, the speed limit of the rotation speed setting is 30,000min⁻¹.

To exit the parameter mode, turn the Main Power Switch ⑨ OFF.

⑩ P 10 Selection of Motor Speed Control Voltage / DC+10V Signal Method

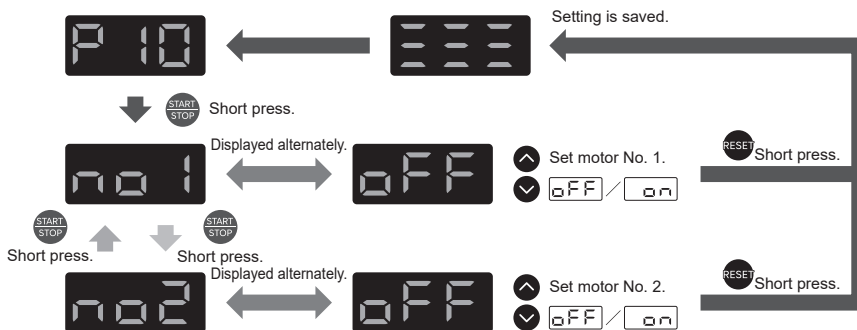

When neither E2280-compatible output nor E2280 motor selection is used: the speed command voltage follows the characteristics of a 60,000 min⁻¹ motor.
When either E2280-compatible output or E2280 motor selection is used: the speed command voltage follows the characteristics of a 50,000 min⁻¹ motor.



When neither E2280-compatible output or E2280 motor selection is NOT used: the speed command voltage follows the characteristics of an 80,000 min⁻¹ motor.
When using E2280-compatible output or E2280 motor selection: the speed command voltage follows the characteristics of a 30,000 min⁻¹ motor.
(Same speed command characteristic as the former E2530 CONTROLLER)

To exit the parameter mode, turn the Main Power Switch ⑨ OFF.

⑪ **P 11** Selection of Emergency Stop Function

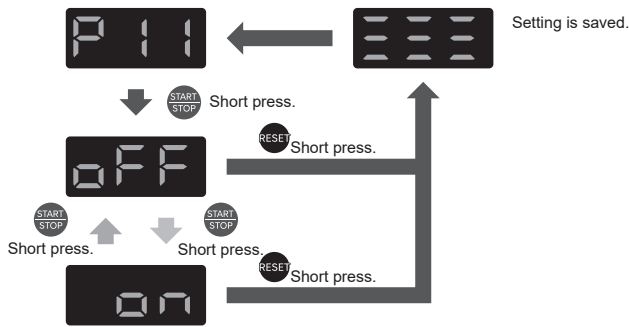

Emergency Stop Function cannot be used.



Emergency Stop Function is activated.

To exit the parameter mode, turn the Main Power Switch ⑨ OFF.

⑫ **P 12** Selection of RUN Signal Output

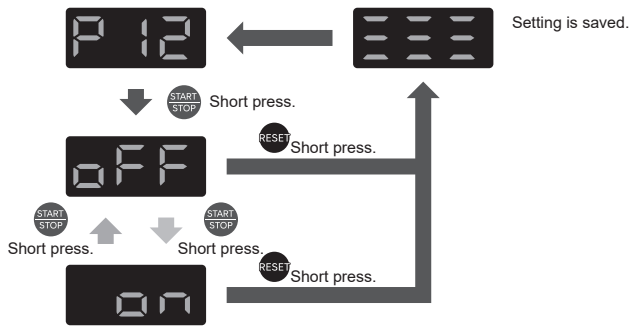

Pin No. 6 (RUN) of the External Input / Output Connector A ③ functions as the motor rotating signal.



Pin No. 6 (RUN) of the External Input / Output Connector A ③ functions as the motor stop signal.

To exit the parameter mode, turn the Main Power Switch ⑨ OFF.

⑬ **P 13** Function Selection of Pin No. 7 of the External Input / Output Connector A ③

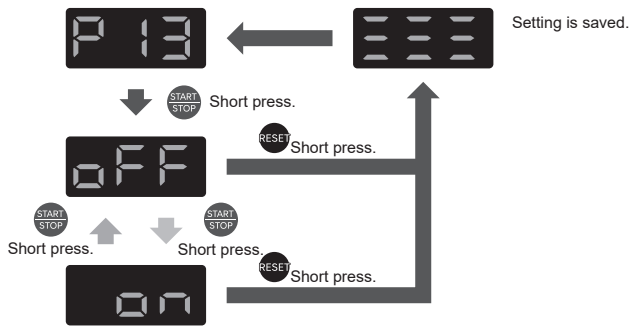

Pin No. 7 of the External Input / Output Connector A ③ functions as the signal for Rotation Direction Setting (DIR_IN).



Pin No. 7 of the External Input / Output Connector A ③ functions as the signal for Motor Selection (SEL_MT).

* If a setting value other than **30** is selected on Parameter **P 14**, this setting is set to **OFF**.

To exit the parameter mode, turn the Main Power Switch ⑨ OFF.

⑭ P 14 Selection of Pin Assignment for the External Input / Output Connector A ③

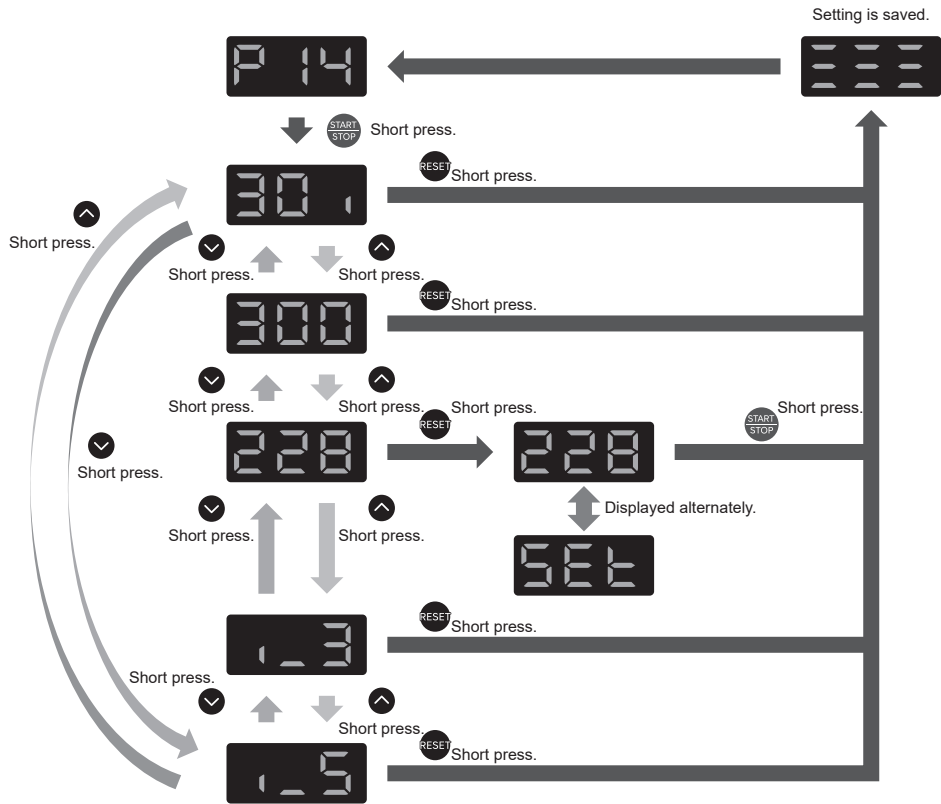

Pin assignment for the External Input / Output Connector A ③ is set to E3000I.



Pin assignment for the External Input / Output Connector A ③ is set to iSpeed3 compatible.



Pin assignment for the External Input / Output Connector A ③ is set to E3000 compatible.



Pin assignment for the External Input / Output Connector A ③ is set to iSpeed5 compatible.



Pin assignment for the External Input / Output Connector A ③ is set to E2280 compatible.

To exit the parameter mode, turn the Main Power Switch ⑨ OFF.

⑮ P 15 Selection of iSpeed5 Motor

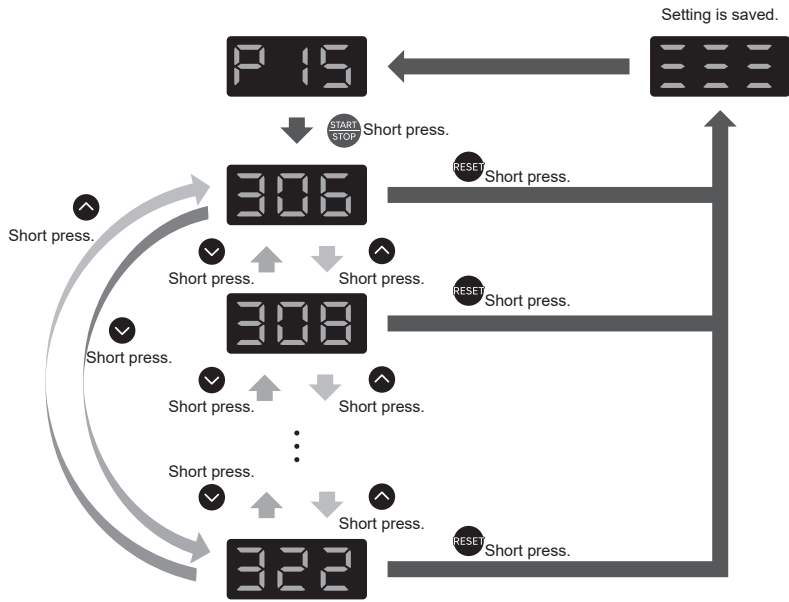

306

The motor EM-3060ATC for iSpeed5 can be used.

320

The motor BM320 for iSpeed5 can be used.

308

The motor EM-3080ATC for iSpeed5 can be used.

322

The motor BM322 for iSpeed5 can be used.

303

The motor EM-3030T-J for iSpeed5 can be used.

This setting is enabled only when Parameter P 14 is set 1_5.

To exit the parameter mode, turn the Main Power Switch ⑨ OFF.

⑩ P 15 Selection of E2280 Motor

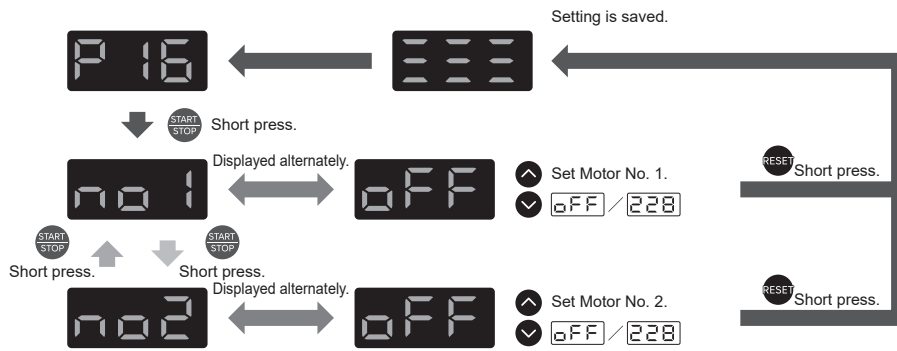

The motors other than those of E2280 can be used.



The motor EM-2350J for E2280 can be used.

*This setting is valid only when Parameter P 14 is set to 30 .

*When Parameter P 14 is set to 228 , it is fixed to 228 .

To exit the parameter mode, turn the Main Power Switch ⑨ OFF.

⑪ P 17 Switching iSpeed5 Motor Air Detection

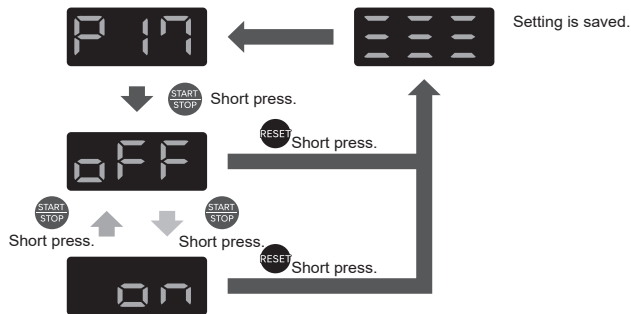

When using an iSpeed5 motor, air detection is disabled.



When using an iSpeed5 motor, air detection is enabled.

*This setting is valid only when Parameter P 14 is set to 1.5 .

To exit the parameter mode, turn the Main Power Switch ⑨ OFF.

⑱ **P 18** Setting Weight of Count Pulse for Speed Setting

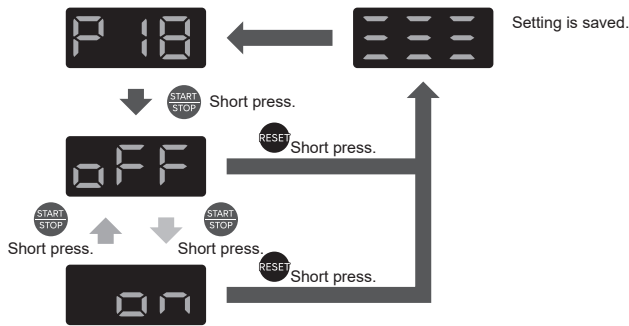

Signal weight of count pulse for speed setting (Pin No. 3: CNT_IN) of the External Input / Output Connector A ③ will be 200min⁻¹/pulse.



Signal weight of count pulse for speed setting (Pin No. 3: CNT_IN) of the External Input / Output Connector A ③ will be 1,000min⁻¹/pulse.

To exit the parameter mode, turn the Main Power Switch ⑨ OFF.

⑲ **P 19** Setting Warning Output / Load Meter Illumination Count Output of Pin No. 20 of the External Input / Output Connector A ③

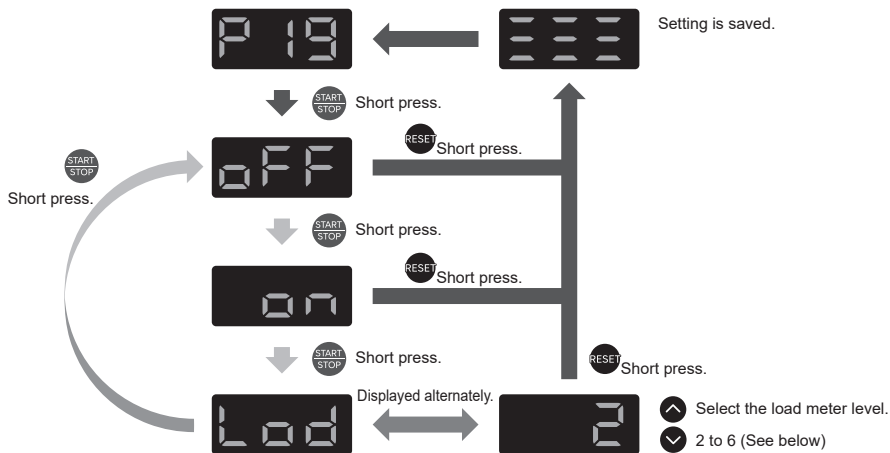

Pin No. 20 (WARNING) of the External Input / Output Connector A ③ is not output.



Pin No. 20 (WARNING) of the External Input / Output Connector A ③ outputs warning signals.



Pin No. 20 (WARNING) of the External Input / Output Connector A ③ is output according to the load meter level.

- 2: If 2 or more load meters illuminate, signal is ON (Closed).
- 3: If 3 or more load meters illuminate, signal is ON (Closed).
- 4: If 4 or more load meters illuminate, signal is ON (Closed).
- 5: If 5 or more load meters illuminate, signal is ON (Closed).
- 6: If 6 load meters illuminate, signal is ON (Closed).

To exit the parameter mode, turn the Main Power Switch ⑨ OFF.

②0 **P20** Setting Motor Acceleration / Deceleration Time

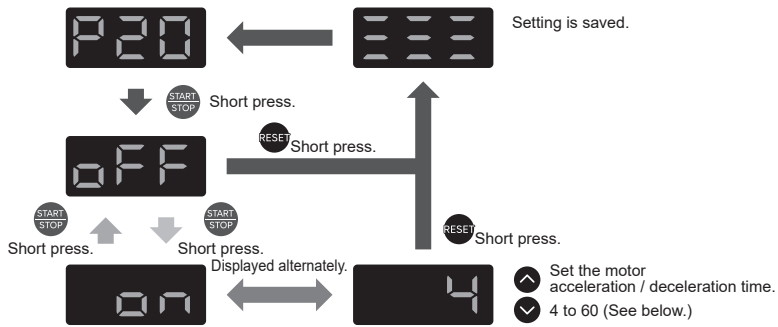

OFF Motor acceleration / deceleration time is set to 2 seconds.

on Set the motor acceleration / deceleration time.

- 4 : 4 sec.
- 6 : 6 sec.
- 8 : 8 sec.
- 10 : 10 sec.
- 12 : 12 sec.
- 14 : 14 sec.
- 16 : 16 sec.
- 18 : 18 sec.
- 20 : 20 sec.
- 25 : 25 sec.
- 30 : 30 sec.
- 45 : 45 sec.
- 60 : 60 sec.

To exit the parameter mode, turn the Main Power Switch ⑨ OFF.

②1 **P21** Setting Speed Achievement Level

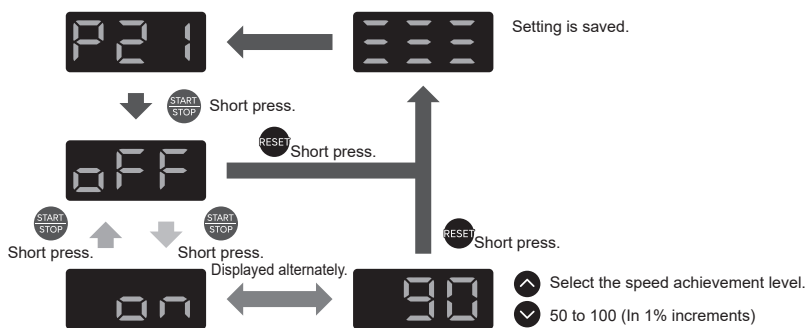





OFF Speed achievement level will be 90%.

on Select the speed achievement level.
50 to 100(%)

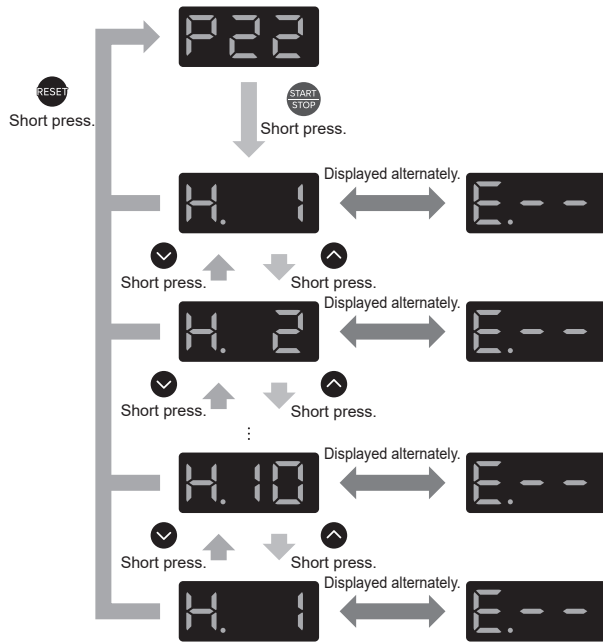
To exit the parameter mode, turn the Main Power Switch ⑨ OFF.

② P22 Error History



-  Indicates the latest error history.
-  Indicates the second error history.
- ⋮
-  Indicates the 10th error history.
-  Error code: "--" is displayed if no error histories to display.

Press and hold (for 3 seconds) the  button to clear the Error History.

To exit the parameter mode, turn the Main Power Switch  OFF.

②③ P23 Motor Usage Cumulative Time

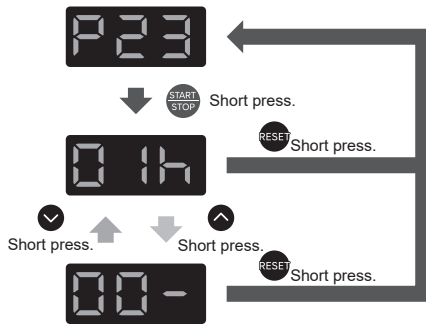

The last 2 digits of motor usage cumulative time are displayed.



The first 2 digits of motor usage cumulative time are displayed.

"00-" or "01h" indicates 1 hour.
"10-" or "00h" indicates 1,000 hours.

Press and hold (for 3 seconds) the button to reset the motor usage cumulative time that is currently displayed to 0.

Switch the Motor No.

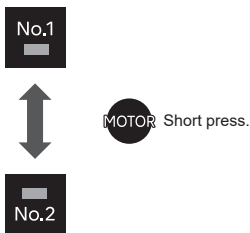

• When the SELECTOR is connected:

The selected motor No. is displayed on the SELECTOR.

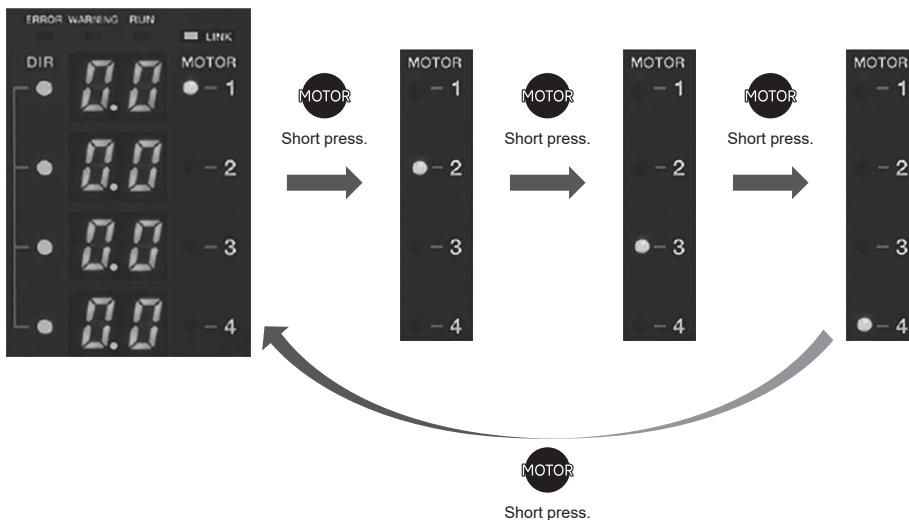

To exit the parameter mode, turn the Main Power Switch ⑨ OFF.

②④ P24 Confirmation of Parameter Setting

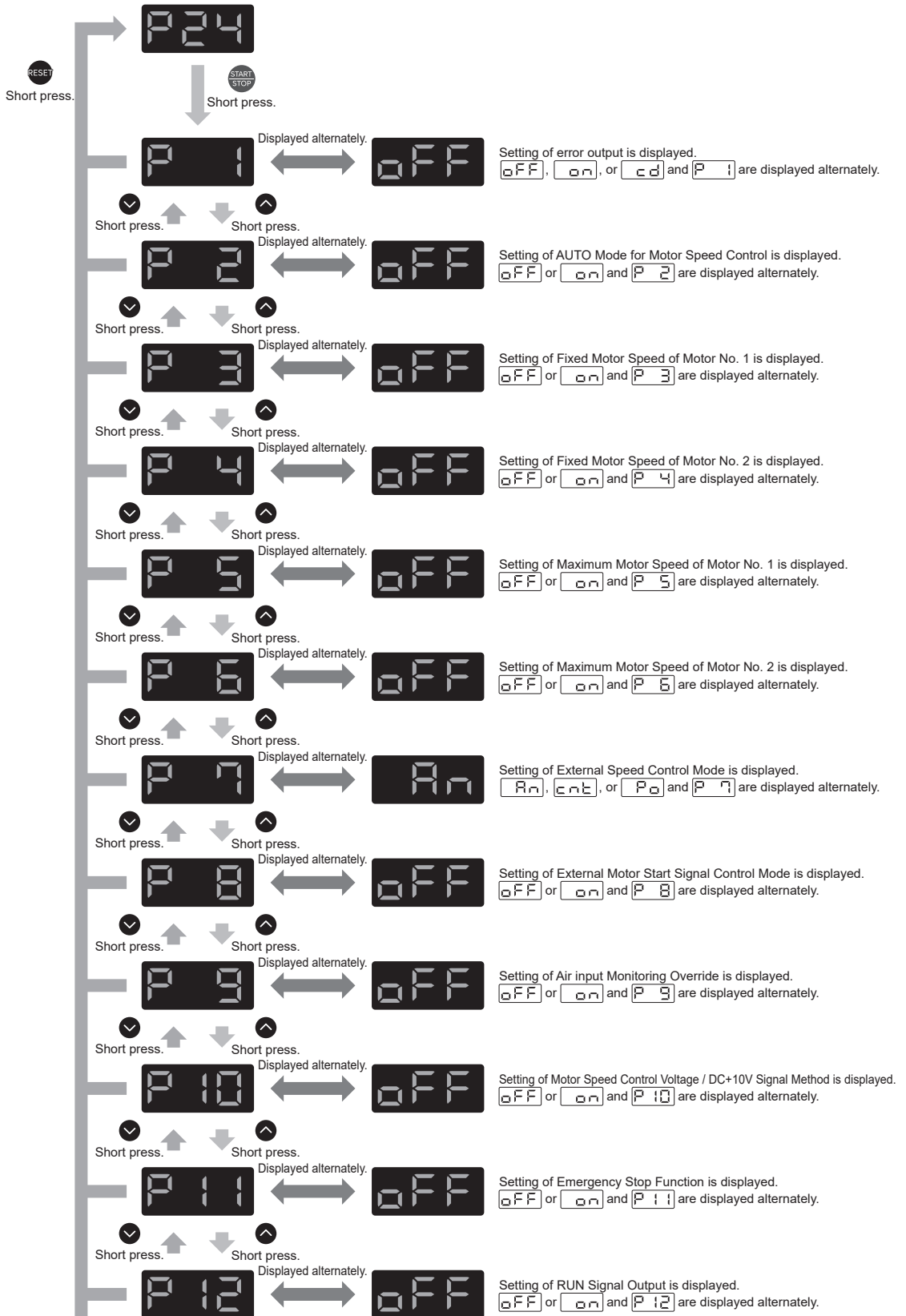

RESET
Short press.

Short press. **P 12** **0FF** Short press. Displayed alternately. Setting of RUN Signal Output is displayed. **0FF** or **00n** and **P 12** are displayed alternately.

Short press. **P 13** **0FF** Short press. Displayed alternately. Setting of Function Selection for Pin No. 7 is displayed. **0FF** or **00n** and **P 13** are displayed alternately.

Short press. **P 14** **30.** Short press. Displayed alternately. Setting of Pin Assignment for External Input / Output Connector A ③ is displayed. Any of **30.** to **1.5** and **P 14** are displayed alternately.

Short press. **P 15** **306** Short press. Displayed alternately. Setting of Selection of iSpeed5 Motor is displayed. Any of **306** to **322** and **P 15** are displayed alternately.

Short press. **P 16** **0FF** Short press. Displayed alternately. Setting of Selection of E2280 Motor is displayed. **0FF** or **228** and **P 16** are displayed alternately.

Short press. **P 17** **0FF** Short press. Displayed alternately. Setting of iSpeed5 Motor Air Detection is displayed. **0FF** or **00n** and **P 17** are displayed alternately.

Short press. **P 18** **0FF** Short press. Displayed alternately. Setting of Weight of Count Pulse for Speed Setting is displayed. **0FF** or **00n** and **P 18** are displayed alternately.

Short press. **P 19** **0FF** Short press. Displayed alternately. The setting for WARNING signal output is displayed. **0FF**, **00n**, or **Load** and **P 19** are shown alternately.

Short press. **P 20** **0FF** Short press. Displayed alternately. Setting of Motor Acceleration / Deceleration Time is displayed. **0FF** or **00n** and **P 20** are displayed alternately.

Short press. **P 21** **0FF** Short press. Displayed alternately. Setting of Speed Achievement Level is displayed. **0FF** or **00n** and **P 21** are displayed alternately.

Short press. **P 1** **0FF** Short press. Displayed alternately.

⋮

21. BREAK IN PROCEDURE

During transportation, storage or installation the grease inside the bearings will settle. If the spindle is suddenly run at high-speed, the lack of evenly distributed grease will cause excessive heat leading to bearing damage.

After installation, repair, initial operation, or long periods of non operation please follow the break-in procedure.

Please refer to the " BREAK IN PROCEDURE " in Operation Manual of the Motor / Spindle.

22. CONNECTION WITH E3000 SELECTOR

22 - 1 Setting

E3000 SELECTOR cannot be used when the parameters are set as follows.

- Parameter P_{14} is set to one of 228 , 13 , or 15 .



22 - 2 Connection and Usage

Connect E3000 SELECTOR to Motor No. 1. Motor No.2 cannot be used.

For connection and usage, refer to E3000 SELECTOR Operation Manual.

23. TROUBLESHOOTING

If a problem or concern occurs, please check the following prior to consulting your dealer.

| Trouble | Cause | Inspection / Corrective Active |
|---|--|--|
| Cannot operate with the Control Panel ② buttons. | Operation with the Control Panel ② buttons is disabled (Key Hold Button ⑳ LED  is lit). | Press and hold the Error Reset Button (RESET) ⑲ for 3 seconds to enable operation with the Control Panel ② buttons. |
| The motor rotation speed cannot be displayed on the Control Panel ②. | The Display Switch Button (DISP) ⑱ is set to " × 10mA" or "MPa". (The × 10mA LED or MPa LED is lit.) | Press the Display Select button (DISP) ⑱ to select × 100 min ⁻¹ . (Turn OFF both the × 10mA LED and MPa LED.) |
| In AUTO Mode, the rotation speed cannot be set by external signals (analog voltage, pulse signal, or speed-point signal). | Parameter P_{2} is set to 00 . (When set to 00 , set the speed with the Motor Speed Adjustment Button ( , ) ⑬ on Control Panel ②.) | Set Parameter P_{2} to FF . (Refer to "20-4 ② P_{2} Setting AUTO Mode for Motor Speed Control" section.) |

| Trouble | Cause | Inspection / Corrective Active |
|---|--|--|
| Motor does not run. | Power is not supplied. | <ul style="list-style-type: none"> • Make sure to turn ON the Main Power Switch ⑨ on the front of the CONTROLLER. • Insert the power cord Plug correctly into the Main Power Inlet with Power Supply Fuses ⑩ of the CONTROLLER. • Check if a fuse is blown. |
| | Motor Cord Plug is not connected to the Motor, CONTROLLER or SELECTOR. | Connect the Motor Cord plug correctly to the Motor and CONTROLLER or SELECTOR. |
| | Incompatible motor or motor spindle is connected to the CONTROLLER. (The Error Code " EL " is displayed on the Digital Speed Indicator ⑪.) | Connect the connectable brushless motor or brushless motor spindle to the CONTROLLER after released the Error Code " EL " (Refer to " 7. SYSTEM CHART " section Fig. 3 to 6). |
| | The connected motor has not been selected. | Select Motor Connector No.1 or No.2 to which a motor is connected. When the control is in AUTO Mode: Refer to "17-2-2 (2)Select the Motor". When the control is in MANUAL: Refer to "17-2-1 (2) Select the Motor". |
| | Control Button (CTRL) ⑰ is set to Manual mode but trying to start with an External Command Signal through External Input / Output Connector A ③. | Start with the START / STOP Button (START / STOP) ⑭, or set the Control Button (CTRL) ⑰ on the Control Panel ② to Auto mode. |
| | Control Button (CTRL)⑰ is set to Auto mode but trying to manually start with the START / STOP Button (START / STOP) ⑭ on the Control Panel ②. | Start with an External Command Signal or set the Control Button ⑰ on the Control Panel ② to Manual mode. (When Start with an External Command Signal, refer to "18 - 1 (1) Details of External Input / Output Connector A ③ Signals Table. 10 Pin No. 14 ") |
| When started the motor, " E.E " is displayed and motor does not rotate. | Emergency Stop Signal is ' OFF (Open) '. | Check the setting of parameter $\boxed{P \ 11}$. (Refer to " 20 - 4 ⑪ $\boxed{P \ 11}$ Selection of Emergency Stop Function " section.) |
| When starting the motor, " E7 " is displayed and motor does not rotate. | Low air pressure. | Refer to " 15 - 2 Setting Air Pressure " section to supply proper air pressure. |
| When starting the motor, " En " is displayed and motor does not rotate. | Pin No. 10 of the External Input / Output Connector A ③ is connected to GND while parameter $\boxed{P \ 14}$ is set to $\boxed{1 \ 3}$. | Match the setting of parameter $\boxed{P \ 14}$ and the wiring of the External Input / Output Connector A ③ . |
| An Error Code occurs and motor does not run. | An Error has occurred. (Error LED (ERROR) ⑳ is lit.) | Check " 19 - 3 Resetting System after Error Codes. Refer to Table 15 ". Error will not be released until cause of the error has been removed. |

| Trouble | Cause | Inspection / Corrective Active |
|---|--|---|
| Can not set the increase or decrease of the motor rotation speed. | When using Motor No.1: The set rotation speed is fixed by Parameter P_{3} or P_{5} . When using Motor No.2: The set rotation speed is fixed by Parameter P_{4} or P_{6} . | Release both "Setting Fixed Motor Speed of Motor" and "Setting Maximum Motor Speed of Motor" in the parameters. For Motor No.1: Refer to "20-4 ③ P_{3} Setting Fixed Motor Speed of Motor No. 1", or "20-4 ⑤ P_{5} Setting Maximum Motor Speed of Motor No. 1". For Motor No.2: Refer to "20-4 ④ P_{4} Setting Fixed Motor Speed of Motor No. 2", or "20-4 ⑥ P_{6} Setting Maximum Motor Speed of Motor No. 2". |
| A mismatch occurs when setting the speed by the count-pulse signal for speed setting. | An unacceptable maximum pulse-train width has been entered. | Refer to Parameter P_{7} . (Refer to "20-3 ⑦ P_{7} Selection of External Speed Control Mode" section.) |
| The speed set by the count-pulse signal does not match. | The weight for the count pulses does not match. | Check the setting of Parameter P_{18} . (refer to "20-4 ⑱ P_{18} Setting Weight of Count Pulse for Speed Setting" section.) |
| Can not set the motor speed to its maximum allowable speed. | Trying to set a speed higher than the connected motor's rotation speed capability. Either the required speed value is higher than the maximum rotation speed of the motor, or the upper limit of the rotational speed has been set in parameter P_{5} or P_{6} . | Check the maximum rotation speed of the connected motor. Also check the settings of Parameter P_{5} or P_{6} . If using Motor No.1: Refer to "20-4 ⑤ P_{5} Setting Maximum Motor Speed of Motor No. 1" section. If using Motor No.2: Refer to "20-4 ⑥ P_{6} Setting Maximum Motor Speed of Motor No. 2".section. |
| | Parameter P_{10} is OFF . | Check the setting of parameter P_{10} . (Refer to " 20 - 3 ⑩ P_{10} Selection of Motor Speed Control Voltage / DC+10V Signal Method " section.) (Refer to " 20 - 4 ⑩ P_{10} Selection of Motor Speed Control Voltage / DC+10V Signal Method " section.) |
| | Air Input Monitoring Override is set in the P_{9} parameter to ON and the motor's maximum speed has been limited to 30,000 min ⁻¹ (rpm). | Check the setting of parameter P_{9} . (Refer to " 20 - 4 ⑨ P_{9} Selection of Air Input Monitoring Override " section.) |
| The rotation speed cannot be changed using speed points. | Parameter P_{7} is not set to P_{0} . | Check the setting of Parameter P_{7} . (Refer to "20-4 ⑦ P_{7} Selection of External Speed Control Mode" section.) |
| | No rotation speed has been set for the speed point. | |

| Trouble | Cause | Inspection / Corrective Active |
|--|---|--|
| The rotation speed cannot be changed using speed points. | The set rotation speed is fixed by Parameter P 3 or P 5 , and by P 4 or P 6 . | Check the settings of Parameter P 3 or P 5 , and by P 4 or P 6 . If using Motor No.1: Refer to "20-4 ③ P 3 Setting Fixed Motor Speed of Motor No. 1", or "20-4 ⑤ P 5 Setting Maximum Motor Speed of Motor No. 1". If using Motor No.2: Refer to "20-4 ④ P 4 Setting Fixed Motor Speed of Motor No. 2", or "20-4 ⑥ P 6 Setting Maximum Motor Speed of Motor No. 2". |
| The RUN signal does not turn ON (closed) when the motor is rotating. | Parameter P 12 is set to on . | Check the setting of Parameter P 12 . (Refer to "20-4 ⑫ P 12 Selection of RUN Signal Output" section.) |
| Parameter P 15 cannot be set. | A value other than 1_5 is selected in Parameter P 14 . | Check the setting of Parameter P 14 . (Refer to "20-4 ⑭ P 14 Selection of Pin Assignment for the External Input / Output Connector A ③ " section.) |
| Parameter P 16 cannot be set. | A value other than 30_1 is selected in Parameter P 14 . | Check the setting of Parameter P 14 . (Refer to "20-4 ⑭ P 14 Selection of Pin Assignment for the External Input / Output Connector A ③ " section.) |
| When using an iSpeed5 motor, A1, A5, or E7 occurs. | Parameter P 17 is set to on . | Check the setting of Parameter P 17 . (Refer to "20-4 ⑰ P 17 Switching iSpeed5 Motor Air Detection" section.) |
| The WARNING is not output. | Parameter P 19 is set to on . | Check the setting of Parameter P 19 . (Refer to "20-4 ⑱ P 19 Setting Warning Output / Load Meter Illumination Count Output of Pin No. 20 of the External Input / Output Connector A ③ " section.) |
| Motor start and stop are slow. | Parameter P 20 is set to on . | Check the setting of Parameter P 20 . (Refer to "20-4 ⑳ P 20 Setting Motor Acceleration / Deceleration Time" section.) |

24. DISPOSAL OF THE CONTROLLER

When disposal of a CONTROLLER is necessary, follow the instructions from your local government agency for proper disposal of industrial components.

取扱説明書のダウンロード ▶
Download operation manual



ウェブサイト ▶
Our website



株式会社ナカニシ

〒322-8666
栃木県鹿沼市下日向700
TEL: 0289-64-3380
FAX: 0289-62-5636
nakanishi-spindle.com

NAKANISHI INC. 

700 Shimohinata, Kanuma
Tochigi 322-8666
Japan
en.nakanishi-spindle.com

NSK America Corp.

1800 Global Parkway
Hoffman Estates
IL 60192, USA
www.nskamericacorp.com

NSK Europe GmbH 

Elly-Beinhorn-Str. 8
65760 Eschborn
Germany

NSK United Kingdom Ltd.

UK Responsible Person
Hertford House
Rutherford Close, Stevenage
Hertfordshire, SG1 2EF, UK